

# The Parts and The Whole

A Holistic Approach to Environmental  
and Sustainability Education

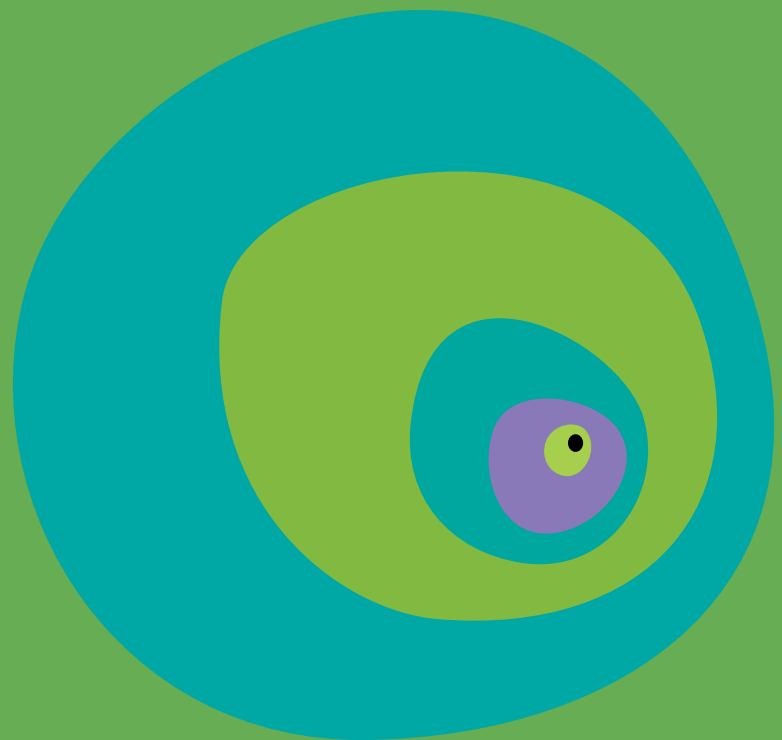

Manual

# The Parts and The Whole

A Holistic Approach to Environmental  
and Sustainability Education

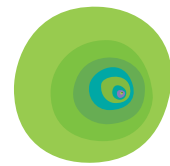



## SWEDES

This teacher education manual is compiled by the Swedish International Centre of Education for Sustainable Development (SWEDES).

*Editorial* Compiling authors: Wolfgang Brunner and Shepherd Urenje  
Scientific Editor: Fredrik Moberg  
Language Editor: Tammy Brown

*Contributing authors* Irma Allen, Magnus Apelqvist, Per Bergstrom, Wolfgang Brunner, Iris Jane Mary Chimbodza, Lilian Chipatu, Dick Kachilonda, Caleb Mandikonza, Fanuel Manyinyire, Timothy Kamuzu Phiri and Shepherd Urenje.

*Suggested reference* Brunner, W. & Urenje, S. (2012). *The Parts and The Whole: A Holistic Approach to Environmental and Sustainability Education*. Visby: Swedish International Centre of Education for Sustainable Development.

*Copyright* This teacher education manual can be reproduced and adapted for research and educational purposes that are not-for-profit, provided the authors (Brunner, W. and Urenje, S.) and the publisher (SWEDES) are duly acknowledged.

The Swedish International Centre of Education for Sustainable Development (SWEDES) at Gotland University was established in 2008. The Centre is financed by Sida, the Swedish International Development Cooperation Agency. It is SWEDES's mission to help develop the capacity of individuals and organizations for enhancing sustainable development.

The publication is available on a number of websites including [www.swedesd.se](http://www.swedesd.se) and [www.sadc-reep.org.za](http://www.sadc-reep.org.za)



This work is licensed under the Creative Commons Attribution-NonCommercial-ShareAlike 3.0 Unported License.

*Layout and illustrations* Helena Duveborg  
*Printed by* Ecoprint, Tartu, Estonia 2012  
*Typeface* Myriad Pro and ITC Galliard  
*Paper* Scandia 2000, FSC™-certified



ISBN 978-91-637-1218-0

# Content

	4	Preface
	5	Introduction
	9	Glossary
Holistic Examples	11	Introduction
	12	The Mission
	16	A Good Life
	18	Ecological Footprint
	20	The Fish Game
Physics	23	Introduction
	24	Cool News for a Hot Planet
	26	The Electric Grid
	32	Nature Works Forwards
Chemistry	35	Introduction
	36	Acid Circumstances
	38	The Carbon Cycle
Biology	41	Introduction
	42	The Parts and The Whole
	44	What are we Doing With Our Water?
	46	The Mystery of the Enclosed Garden
Geography	49	Introduction
	50	The Bee-Keeper's Story
	52	The Happy Planet
	54	The Story of the Invisible Water
Social Studies	57	Introduction
	58	Myths and Legends
	60	Sustainable Consumption
	62	Fairness and Strong Sustainability
Business Studies	65	Introduction
	66	Chocolate, Slavery and Fair Trade
	68	Cell Phones, Gorillas and Armed Conflicts
	70	Economic Responsibility

# Preface

The interconnected environmental, economic, social and political challenges facing humanity demand capable and responsible citizens who can make informed choices and take appropriate action to create the conditions for social, economic and environmental sustainability – locally and globally. Education and lifelong learning are essential requisites for making those choices and taking such action.

This teacher educators' manual is aimed at inspiring and being a source of ideas, tools and methods that can help to enrich actual teaching practice. The manual illustrates how possible and exciting it is to try out new perspectives and new methods.

By using and adapting the examples and suggestions in this manual, teacher educators can introduce sustainability issues and challenges into lessons which are usually organized around a single subject, such as Physics or History. The manual emphasizes the interconnectedness of all life phenomena – biological, physical, social, economic, political and cultural. It encourages teacher educators to go beyond the boundaries of their own subject matter or discipline and to consciously incorporate knowledge, insights and perspectives from other disciplines. It also encourages them to actively collaborate with other teacher educators and “outsiders”, so as to make the official curriculum more interesting and relevant to the lives and conditions of their students.

This manual has been prepared for teacher educators, in the first place. But it can be used by any school teacher. Whether working with older or younger children or even adults, they can find ideas and inspiration for their daily work. The content and methods of this manual can be easily brought in tune with the specific conditions of teachers, their schools and their students.

The manual is part of a programme of strengthening the ESD capacity of teacher education institutions, which SWEDESD started in 2010, together with the SADC Regional Environment Education Programme and the Centre of Environment Education (India). It is funded by Sida, the Swedish International Development Agency.

The manual has been prepared in a collaborative process involving seven different organizations in Sweden and Southern Africa as follows:

*Southern African Development Community Regional Environment Education Programme (SADC REEP)* at the Wildlife and Environment Society of South Africa (WESSA), South Africa.

*School of Education, University of Zambia (UNZA)*, Zambia.

*Belvedere Technical Teachers' College (BTTC)*, Zimbabwe.

*School of Education and Communication*, Jönköping University, Sweden.

*Swedish International Centre of Education for Sustainable Development (SWEDESD)* at Gotland University, Sweden.

*Swaziland Environmental Authority (SEA)*, Swaziland.

*Rhodes University, Environmental Education and Sustainability Unit*, South Africa.

I acknowledge their enthusiasm, creativity and dedication and thank them wholeheartedly for their contributions.

This is the manual's first edition. We expect that practicing teacher educators will keep us informed about how well the manual is meeting their expectations and requirements and where it can be improved or expanded in order to be as useful as they wish it to be. With their feedback this manual can become a living source of inspiration and guidance for sustainability education and learning.

Frans Lenglet  
Director  
Swedish International Centre of Education for Sustainable Development at Gotland University

# Introduction

## Winds of change in the education system

It is now widely apparent and acknowledged that humanity's current use of the biosphere (that sphere that embraces all life forms, air, water and land on the planet) is not sustainable. This insight will sooner or later have a profound influence on the entire school and education system worldwide – from curriculum development to everyday teaching in the classrooms. Business as usual is no longer an option.

This realisation that we are pushing the planet's limits will require a more holistic view to education. It implies more of an inter-disciplinary approach and better linkages among the different school subjects, as well as a growing need for more thematic teaching. The education system will also have to set new goals, both at the level of complexity that the learners have to embrace and on producing learners with increased capacity to act. By combining a deeper and more integrated understanding with social and collaborative learning, students will explore making sustainable choices and decisions about their own lives, the lives of others and their common environment. Social and collaborative problem solving, decision making and capacity to make informed choices are central characteristics of AGENCY, the ability to act.

This profound shift of the goals of our education systems is a worldwide process with a large number of actors assembled under the heading "Education for Sustainable Development" – ESD.

## Education for Sustainable Development (ESD)

This teacher education manual is based on the concept of Education for Sustainable Development. ESD recognizes the interdependence of environmental, social and economic perspectives and the dependence of humanity on a healthy biosphere. It is a new way of thinking which has been embraced by the United Nations Decade of Education for Sustainable Development (DESD) 2005–2014. UNESCO, which is leading the Decade, has described its aim as:

*The overall goal is to integrate the principles, values and practices of sustainable development into all aspects of education and learning. This educational effort will encourage changes in behaviour that will create a more sustainable future in terms of environmental integrity, economic viability and a just society for present and future generations. As such ESD seeks to prepare people to cope with and find solutions to problems that threaten the sustainability of the planet.*

UNESCO has emphasized that ESD should be locally relevant. It should be based on local needs, perceptions and conditions. It should acknowledge that fulfilling local needs often has international effects and consequences. It should build civil capacity for community-based decision-making, social

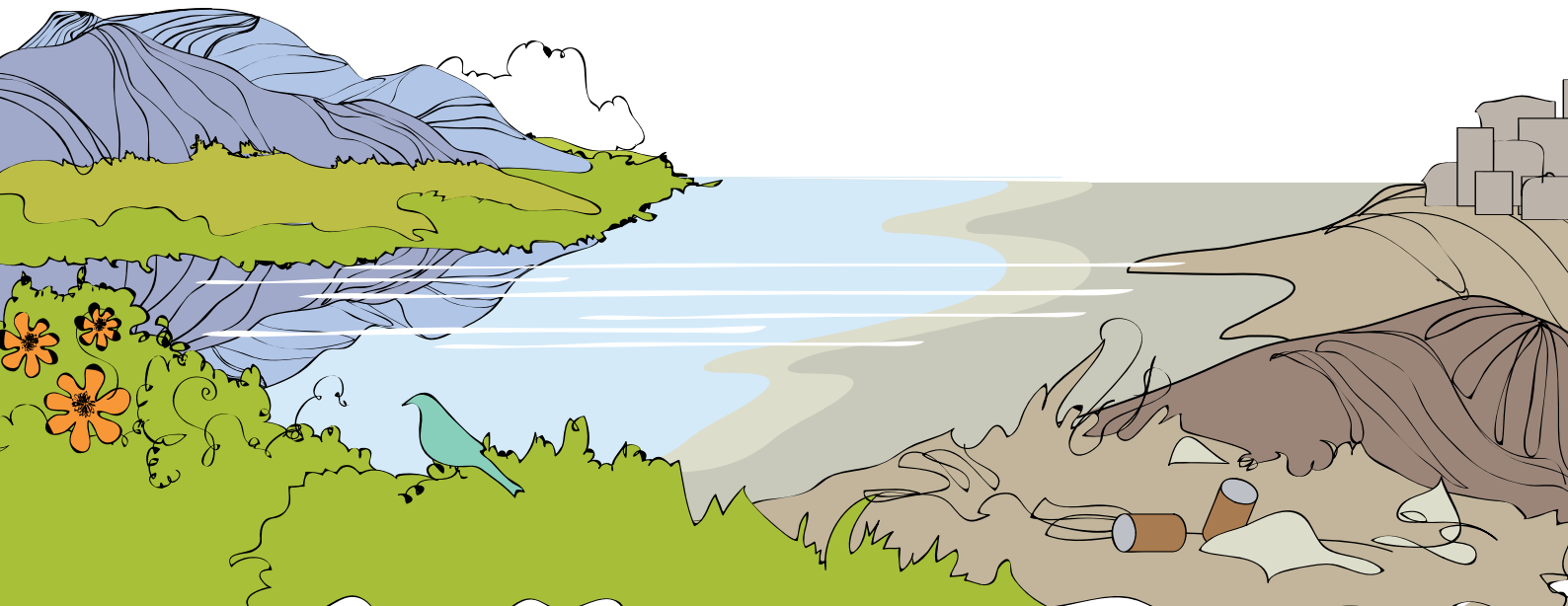

tolerance and quality of life. Moreover ESD is interdisciplinary: no one discipline can claim ESD as its own. However all disciplines can contribute to ESD! This manual is our humble contribution to this worldwide change process.

### Some key elements in ESD

What type of knowledge, insights and perspectives should be added to our teaching in order to contribute to sustainable development? Which new methods, views and approaches will enhance the learner's ability to make informed choices and also to act for the common and ecological good? In our work we have come up with the following:

### Understanding systems

Much of western culture's scientific knowledge has been derived by breaking a problem into components, studying each part in isolation, and then drawing conclusions about the whole. It now has become evident that many of the complex problems we are facing also need a more holistic and systemic approach. A deeper understanding of how different types of systems work is one important aspect in this context.

Understanding systems has many dimensions; here are some we have highlighted in our material:

#### *Biological system levels*

All life on our planet can be viewed as a gigantic organism made up of interconnected units at different system levels ranging from single cells to the whole biosphere. Based on this point of view, we can

also find some of the fundamental relationships that enable parts to work together and to create a functioning whole at each higher level of complexity. Every part or unit has its own borders and integrity. Every part also strives to expand and stay alive. Through the forces of natural selection and self organization these units have developed methods for their own survival and also contribute to the wellbeing and survival of the systems they are part of. The result is that they, as individuals, are in turn supported by their system. This insight provides us with a view that contributes to the discussions on creating a sustainable society, or as the American ecological economist Professor Robert Costanza puts it, "Ecosystems are our best models for understanding sustainable systems".

#### *Flow of energy and resources*

All living systems need energy and different types of raw materials for their survival. This can be maintained by a linear flow within cells and organisms, since these get their resources from their close surroundings. At the ecosystem level and in the biosphere, a linear flow is unsustainable. At these levels there is an absolute demand for the recycling of resources and waste products. The richness of species in mature ecosystems reflects the fact that biodiversity is also crucial for efficient recycling.

These insights also have applications for the understanding of how to create sustainable energy use and resource management in our societies as well as a deeper appreciation of how humans, through all ecosystem services, are connected to nature.

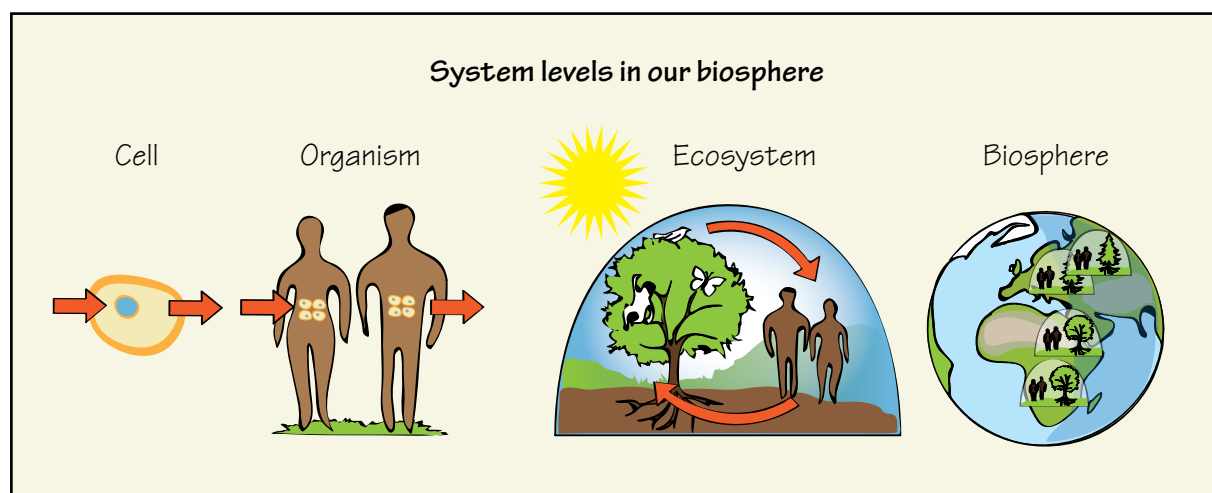

### *Boundaries, resilience, tipping points*

Although many biological systems are strong and resilient they all have their boundaries and tipping points, beyond which they will collapse or behave in a chaotic or unforeseeable way. Lately there have been attempts to identify a “safe planetary operating space” as a guideline for our society’s interaction with nature. Professor Johan Rockström, Director of the Stockholm Resilience Centre puts it like this: “The human pressure on the Earth System has reached a scale where abrupt global environmental change can no longer be excluded. To continue to live and operate safely, humanity has to stay away from critical ‘hard-wired’ thresholds in the Earth’s environment, and respect the nature of the planet’s climatic, geo-physical, atmospheric and ecological processes”.

This appreciation of the necessity for humanity to stay within a “safe planetary operating space” is also a new perspective that we have to bring into our teaching and teacher training.

### *Human society as part of the biosphere*

From the above we can conclude that our education system has to find new innovative ways to vitalize and deepen the insight of our society’s connectedness to nature and its absolute dependency on continuous ecosystem services. At the same time this strong sense of dependency is challenged by the fact that we humans have become the major driving force of global environmental change, even more extensive than volcanic eruptions, plate tectonics and erosion. The earth scientists have in recent years even created a name for this new era in the history of our planet; they call it the Anthropocene, the age of humans!

Hence, we humans are and will forever be part of the biosphere; connected to nature both in our demand for life supporting services and through the fact that we as dominant actors exercise strong influence on the system. Humans are dependent and dominating at the same time!

### *The need for systemic change*

Another realisation stemming from systems thinking is that too often we try to solve environmental problems through quick-fixes that address the symptoms rather than the root of the problems. Instead, we should strive for more fundamental changes based on a deeper understanding of socio-political dilemmas and ecological dynamics. In other words, successful solutions to environmental problems require a systemic view and treatment of the fundamental causes

of problems (like poverty, inequity, property rights, consumption patterns, lifestyle, population growth and economic policies), not only the symptoms.

### **Agency – the ability to act**

The urgent need for more holistic and integrated knowledge as presented above, calls for a shift to greater complexity that learners have to understand and to producing learners with increased capacity to act. This will influence the methods, approaches and tools we use when educating future generations for the challenges ahead.

What does this mean for our education system? As we see it, we will still do most of our teaching within the traditional subjects. Bringing in the holistic or systemic perspectives might be accomplished by just a minor shift in the approach to learning or the description of the final goal. On many occasions there will be a demand for a deeper and more lasting understanding. Knowledge elements from different learning areas studied under different time periods will have to be brought together. Learning at a higher level of complexity might call for more collaboration among the teachers and the use of methods and approaches that will encourage creativity, initiative and critical thinking among learners. Instead of being viewed as an extra burden, these demands both on the teacher and the learner could create conditions that facilitate the work and improve the results.

This material will support learners in developing the ability and willingness to act on sustainability issues by strengthening key competencies such as experience, reflection, knowledge, vision for a sustainable future and systems thinking. In our material we have highlighted examples that illustrate new qualities and methods that can lead to a deeper and more integrated understanding and in doing so, also create more agency among our learners.

### **Some pedagogic strategies in ESD**

When teaching about complex and interconnected issues, it is sometimes difficult to find a good starting point for the learners to explore the unknown and discover pathways that lead to a better overview and deeper understanding of the whole. In this material we will present some strategies on how to overcome this type of difficulty:

#### *Let the learners build*

One way of dealing with complex and interconnected issues is to let the learners themselves gradually build up a holistic understanding. By using a lear-



ning process where the learner is the active agent we combine two vital pedagogic elements:

- The gradual buildup of knowledge will be in line with the learners capabilities/experiences.
- The knowledge elements will become strongly integrated and due to that, also provide the learner with the necessary overview.

The example *The Mission* (page 12) is an illustration of such a process. Out of a few initial conditions and the question: “What will you bring?” the learners will explore and combine a vast field of knowledge areas and through the guidance of a dedicated facilitator they will eventually be able to describe a detailed and rich model of a sustainable world.

### *Models*

Instead of dividing complex issues into separated parts we can simplify them by using smaller but still holistic models. In doing so we can preserve the interplay and dynamics between the parts and facilitate the understanding of how the entire system works. *The Mystery of the Enclosed Garden* (page 46) can simultaneously function as a simplified model of an ecosystem, represent the spaceship in *The Mission* (page 12) or even represent the entire biosphere, as illustrated in *The Parts and The Whole* (page 42).

### *Games and simulations*

Another way of gaining a deeper understanding of the interplay and dynamics in complex issues is to explore them by games, role plays and simulations. *The Fish Game* (page 20) and *Economic responsibility* (page 70) are two examples of such: learners will gather the desired insights and knowledge through a creative exploration process together with their classmates. Through discussions and flashbacks we can help the students in processing their experiences and consolidate what they have learned.

Concepts such as “sustainability”, “planetary boundaries” and “ecosystem services” are very complex and exceed traditional subject borders. Therefore they often call for the use of new approaches and for us to consciously strive to find appropriate lesson sequences and, when necessary in our planning, also collaborate with colleagues teaching other subjects. Examples include *The Happy Planet* (page 52) and *The Story of The Invisible Water* (page 54).

### *Problem based learning*

Problem-based learning (PBL) is a learner-centered pedagogy in which students learn about a subject

in the context of complex, multifaceted, and realistic problems. This type of learning often fits in very well with the goals we are striving for in ESD. Working in groups, learners identify what they already know, what they need to know, and how and where to access new information that may lead to a resolution of the problem. The example *A Good Life* (page 16) is an illustration of this type of learning process.

The goals of PBL are to help the learners develop flexible knowledge, effective problem solving skills, self-directed learning, effective collaboration skills and intrinsic motivation. All this will also increase their agency – their ability to act. Examples include *Sustainable Consumption* (page 60) and *Fairness and Strong Sustainability* (page 62).

### **How the material is organized**

The manual consists of two resources: a teacher education manual and a file with student worksheets linked to examples in the manual. The teacher education manual is structured as follows:

1. The philosophical background to the development of the two materials.
2. An overall introduction to the manual and linked student worksheets.
3. Four holistic examples that cut across all learning areas, each with an introduction for the facilitator and a summary of linked student worksheets.
4. Three examples from each of the six learning areas. For each example there is an introduction for the facilitator and a summary of the linked worksheets.

In addition to the teacher education manual, student worksheets linked to each example are in a separate folder. Supplementary examples and worksheets can be added to this folder by the facilitator.

### **Our approach**

This teacher education manual has chosen to begin in the classroom with the assumption that during their training, student teachers will be exposed to a variety of examples for teaching sustainability which they are most likely to use in their teaching practice. These examples can also be adapted to suit the different classroom conditions. Teacher education will support student teachers to scale the complexity up or down depending on the level of their learners. The material is a stimulation package which will continue to be modified and added to.

# Glossary

**acidification** The changes in the chemistry of the world's seas, soils and freshwater systems as a result of burning fossil fuels and mining processes.

**albedo** The percentage of radiation reflected back by a surface. For solar radiation the albedo indicates the percentage of solar energy that is not absorbed. Darker bodies generally have a lower reflectivity value, a lower albedo.

**biofuels** A renewable source of energy, which is produced by biological material or biomass, such as charcoal, wood pellets, sugar cane, corn, cellulose or vegetable oils.

**biosphere** The global sum of all ecosystems. It can also be called the zone of life on Earth, a closed (apart from solar and cosmic radiation) and self-regulating system.

**carbon cycle** The biogeochemical cycle by which carbon is exchanged among the biosphere, geosphere, hydrosphere and atmosphere of the Earth. It is one of the most important cycles of the Earth and allows for carbon to be recycled and reused throughout the biosphere and all of its organisms.

**carbon sink** Anything that absorbs more carbon than it releases. The main natural processes that create carbon sinks are performed through the buildup of biomass through photosynthesis and by chemical and biological absorption by the oceans.

**climate change** A significant and lasting change in the distribution of weather patterns including temperature, precipitation, humidity, wind and seasons. These changes occur over long periods of time ranging from several decades to millions of years.

**commons** Resources that are owned collectively or shared among communities. These forms of wealth which belong to all of us are said to be "held in common" and ought to be actively protected and managed for the good of all.

**ecological footprint** A measurement that represents the amount of biologically productive land and sea area, necessary to supply the resources a human population consumes and to assimilate the waste they generate.

**ecosystem services** The benefits that people get from a variety of resources and process that are supplied by natural ecosystems, e.g. provision of clean water,

regulation of climate, pollination of crops and fulfilment of people's cultural needs.

**electric grid** An interconnected network for delivering electricity from suppliers to consumers.

**electronic waste** All discarded electronic equipment that is at the end of its useful life including computers, televisions, VCRs, stereos, copiers and fax machines.

**social equity** An equal opportunity for all citizens in a safe and healthy environment.

**fair trade** An approach to trading which aims to ensure that producers get a fair deal for their work. This includes a fair price for goods and services, decent working conditions, and a commitment from buyers for a reasonable income for the producers.

**fairness** A commitment to credit to each person his or her entitlement.

**fossil fuels** Fuels formed by natural processes such as anaerobic decomposition of buried dead organisms. Fossil fuels contain high percentages of carbon and include coal, petroleum, and fossil gas.

**global hectares** (gha) A common unit that quantifies the bio capacity of the earth. A global hectare indicates the average biologically productive area available per person worldwide. Global hectares are used to compare human demands on nature with the biosphere's ability to regenerate resources and assimilate waste.

**global warming** The rise in the average temperature of the earth's atmosphere and oceans since the late 19th century, and its projected continuation.

**greenhouse effect** A process by which thermal radiation from a planetary surface is absorbed by atmospheric greenhouse gases, and is re-radiated in all directions. This re-radiation is directed back towards the earth's surface and the lower atmosphere and results in global warming.

**holism** The idea that natural systems (physical, biological, chemical, social, economic, mental, linguistic, etc.) and their properties, should be viewed as wholes, not as collections of parts. This often includes the view that systems somehow function as wholes and that their functioning cannot be understood solely in terms of their component parts.

**planetary boundaries** The boundaries that delineate a “safe operating space” for humanity. A concept developed by a group of researchers in 2009 to describe nine safe biophysical boundaries outside which the Earth System cannot be pushed without disastrous consequences. The nine critical planetary boundaries are climate change, biodiversity loss, excess nitrogen and phosphorus production, stratospheric ozone depletion, ocean acidification, global consumption of freshwater, change in land use for agriculture, air pollution, and chemical pollution.

**recycling** Recycling is processing waste into new products to prevent waste of potentially useful materials to reduce the consumption of fresh raw materials, reduce energy, usage to reduce air pollution and water pollution.

**reductionism** An approach to understanding the nature of complex things by reducing them to the interactions of their parts, or to simpler or more fundamental things.

**resilience** The long-term capacity of a system to deal with change and continue to develop. For an ecosystem such as a forest, this can involve dealing with storms, fires and pollution, while for a society it involves an ability to deal with political and economic uncertainty or natural disasters in a way that is sustainable in the long-term.

**strong sustainability** The concept of strong sustainability is based on the scientific fact that all human life and activity occurs within the limitations of planet Earth, or the ‘biosphere’ where humankind lives, including all societal functions, such as the economy. Without a functioning biosphere there can be no society and no societal functions including an economy.

**tipping point** The critical point in a changing situation that leads to a new and irreversible development; a point when a system changes from one state to another state.

**tragedy of the commons** A dilemma arising from the situation in which multiple individuals, acting independently and rationally consulting their own self-interest, will ultimately deplete a shared limited resource, even when it is clear that it is not in anyone’s long-term interest for this to happen.

**virtual water** Virtual water refers, in the context of trade, to the water used in the production of goods or services.

**water footprint** The total volume of freshwater used to produce the goods and services consumed by an individual or a community or produced by business.

# Holistic Examples

As mentioned in the introduction, the alarming environmental problems we are facing will require a more holistic view to education. It implies more of an inter-disciplinary approach and better linkages among the different school subjects, as well as a growing need for more thematic teaching. At the same time, in order to be able to work with holistic and thematic approaches, the learners need a lot of specified and detailed knowledge provided by traditional subject studies. The challenge is to combine these supposed contradictions and find ways to let our teaching within traditional subjects be influenced by holistic and trans-disciplinary perspectives.

The example **The Mission** is a good illustration of that. It is a holistic task where the learners use knowledge and insights from many subject areas. The goal is that they, at their own level of understanding, should create a model of a sustainable world. Out of a few initial conditions and the question – “What will you bring?” – the learners will explore and combine many knowledge areas and in the end will be able to describe a detailed and rich model of a sustainable world.

The example **A Good Life** could be used as a shorter version of the same theme. The learners will, through a guided process of group discussions and plenary sessions, explore ethics, values and other basic elements that contribute to “a good life” in a sustainable society.

The eco-footprint is a very useful tool when discussing environmental sustainability and making life style comparisons between nations or individuals. The concept is a complex and advanced tool that calls for solid background knowledge from a number of subject areas. In the example **Ecological Footprint** we introduce the concepts of eco-footprints, bio capacity and supply and demand for resources. We give the learners a basic understanding of how eco-footprints are calculated and also of how they are influenced by human behaviour.

“The tragedy of the commons” is an explanation of why common resources all over the world have often been depleted because the responsibility of safeguarding them is not tied to the individual. The example **The Fish Game** allows the learners to gain a deeper understanding of the driving forces and challenges with resource management of commons, and equips them with tools, knowledge and values on how best they could reduce the risks of over-exploitation.

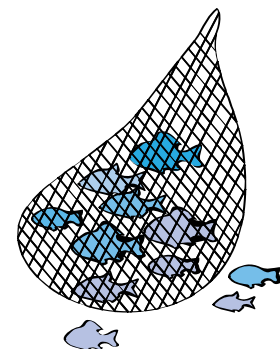

# Holistic Examples

Ecology  
Ecosystem services  
Sustainability  
Planetary boundaries

Natural sciences  
Social sciences

## Objectives

- Discover vital elements in a sustainable world.
- Combine these elements to create a model of a sustainable world.
- Discuss and describe ethical and social frameworks for a sustainable relationship between Man/Society and Nature onboard the spaceship.
- Link the outcomes of this work to sustainability issues in our society and on a global scale.



2–4 hours

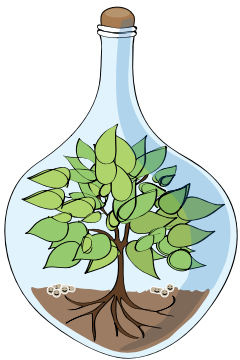

## The mini ecosystem

It is a great help to have prepared a closed mini ecosystem when launching this task (see page 47). Don't hint directly towards the bottle, but let it be a visible object during their work. Sooner or later the students will notice it and include it in their discussions.

# The Mission

## Introduction

The Mission is a holistic task where the learners use knowledge and insights from many subject areas. The goal, as pointed out in the objectives, is that the learners, at their own level of understanding, should create a model of a sustainable world.

The task can be used for different purposes, for instance:

- as an *examination task* for the learners to see if they can merge knowledge from many subject areas into a functioning and sustainable whole.
- as an *evaluation* for us teachers to determine if our teaching has led to the aspired qualities for understanding sustainability issues.
- as an *introduction* to academic courses with sustainability content.

The manual below focuses on how to use The Mission as an examination task for learners half way through, or at the end of secondary school.

## Reminder to the teacher

As we give our learners this extraordinary task we also start a development process where the learners are the main actors. This means that we as facilitators of the process should adopt a somewhat restrained and cautious attitude:

- Never reject a proposal or an idea – even “wild ones”. Let the learners argue and discuss, allow them even to go into directions you already know will lead to dead ends.
- Don't come up with ready-made solutions to their problems but stimulate their thinking and creativity by meeting them in serious discussions at their level.
- Provide them with tools to handle the many aspects they have to embrace and help them to organize their discussions.

## Working process

### Start

1. Hand out the instructions and let the learners consider the task individually for 5 minutes. No discussions are allowed and instruct them to make notes of whatever comes to their minds.
2. Form groups of 4–6 persons and within their group ask each of them to read what they have written down, without any long explanation. As a group, the learners work together with the common goal that:

*“The interior of your spaceship should be so well-equipped, smart and inviting that all the others in the end would like to join your spaceship!”*

A simple suggested contour of the spaceship could be helpful in the face of this process.

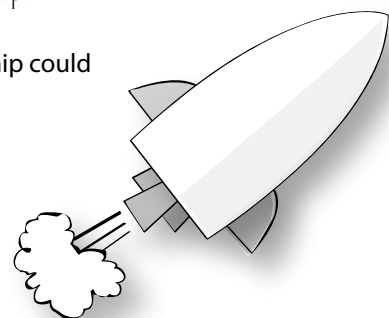

### **Tools to organize and structure their discussions**

After a while their spaceships will be filled with all the items and functions they have thought of in their discussions and they may need some structuring tools. Below you will find some suggestions:

#### *To find a starting point*

One way of organizing their discussions is to suggest to them that they use Maslow's "hierarchy of needs" and advise the learners to start with finding solutions for the most "fundamental needs". Later on they can tackle the ones higher up in the hierarchy.

#### *No waste hatch*

Some groups may have the idea that they can solve all their problems by just creating huge store-rooms filled with all they will need for the entire journey. Challenge their "linear flow" ideas by introducing the fact that "there is no waste hatch so you can't throw your garbage into space!"

#### *The inner space and the size*

Some groups may run into difficulties if they design their spaceships with many floors, staircases and elevators. Suggest to them that they group all the essential life functions on one floor and start to design that one.

A key aspect of creating an inner space may evolve from their discussions on the water issue. Encourage them to find a "natural way of creating a water cycle". For this discussion the mini ecosystem (see page 47) could be a useful model. By making sure that the learners address the water issue at early stage, we also help them to create the inner space that will contribute to the solutions of many other challenges.

At this point learners may raise questions about the size of their spaceship. We can let them decide themselves, but at the same time point out to them the fact that on planet Earth each person has access to 2 hectares per person (expressed as ecological footprint), if distributed equally!

#### *Gravity*

After a while some of the learners may comment on the lack of gravity onboard their spaceship. Congratulate them on that finding and reward them by offering free gravity of exactly the strength they prefer. Without gravity they will have to rotate their ship and therefore the design will become much more difficult.

#### *More to come*

There will of course be many more challenges for the learners and it is up to us as facilitators to inspire and encourage them not to give up. The fact that they are building their own world and they themselves are the main actors often contributes to their engagement and pride in what they have accomplished.

# Holistic Examples

Ecology  
Ecosystem services  
Sustainability  
Planetary boundaries  
Natural sciences  
Social sciences

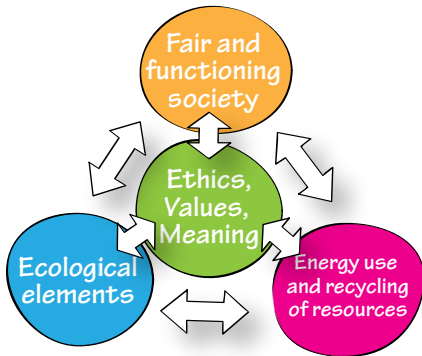

## Sustainability

As mentioned in the objectives this task is about the learners building a model of a sustainable relationship between humans and ecosystem. In doing so, they will make increasing comparisons with the conditions on planet Earth. This gives us facilitators many opportunities to introduce and consolidate the understanding of core concepts within the sustainability realm, such as: biodiversity, ecological footprint, ecosystem services, resilience, planetary boundaries.

Understanding sustainability issues always demands a holistic perspective in which the learners have to consider a number of interconnected aspects at the same time. The fact that they have built their own world and the simplified overview that the spaceship provides will help them in this process. In the diagram on page 15 you have an overview of aspects and vital elements they might encounter. The skills of your learners and the time provided will determine how far you can reach.

## Final statement

The final outcome of their work can be presented in many different ways, for example:

- as an exhibit with maps and illustrations of their spaceship, descriptions of vital functions and highlighting special qualities and smart solutions.
- as a written report where each learner summarizes and reflects on what they have achieved during their group work.

**Holistic Examples**  
The Mission  
worksheet **1**

## The Mission

**Worksheet 1**

You have been appointed by the Planetarian Council to plan and take part in the greatest adventure in the history of mankind. You shall equip a giant spaceship to make a journey into space and the future. These are the conditions:

- The journey will last for 6000 years.
- You will have access to a shining sun throughout the journey.
- No more than 100 persons are allowed onboard the ship at the same time.

What will you bring?

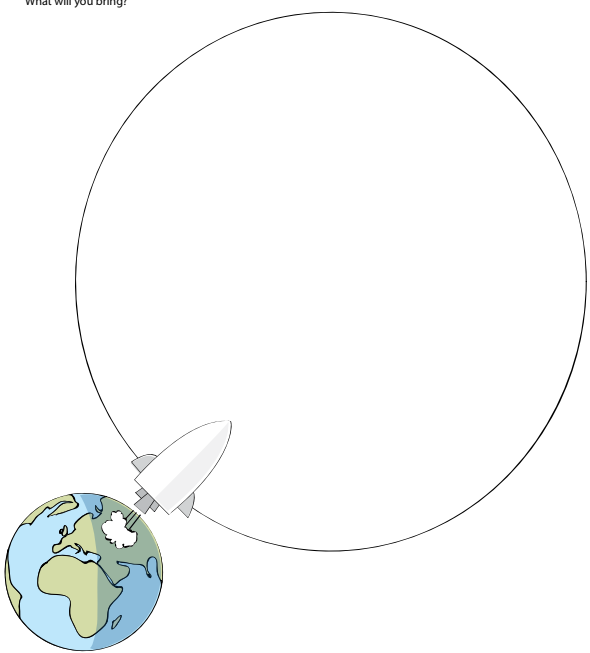

4

This schedule presents an overview of some of the knowledge areas the learners might address in their discussions.

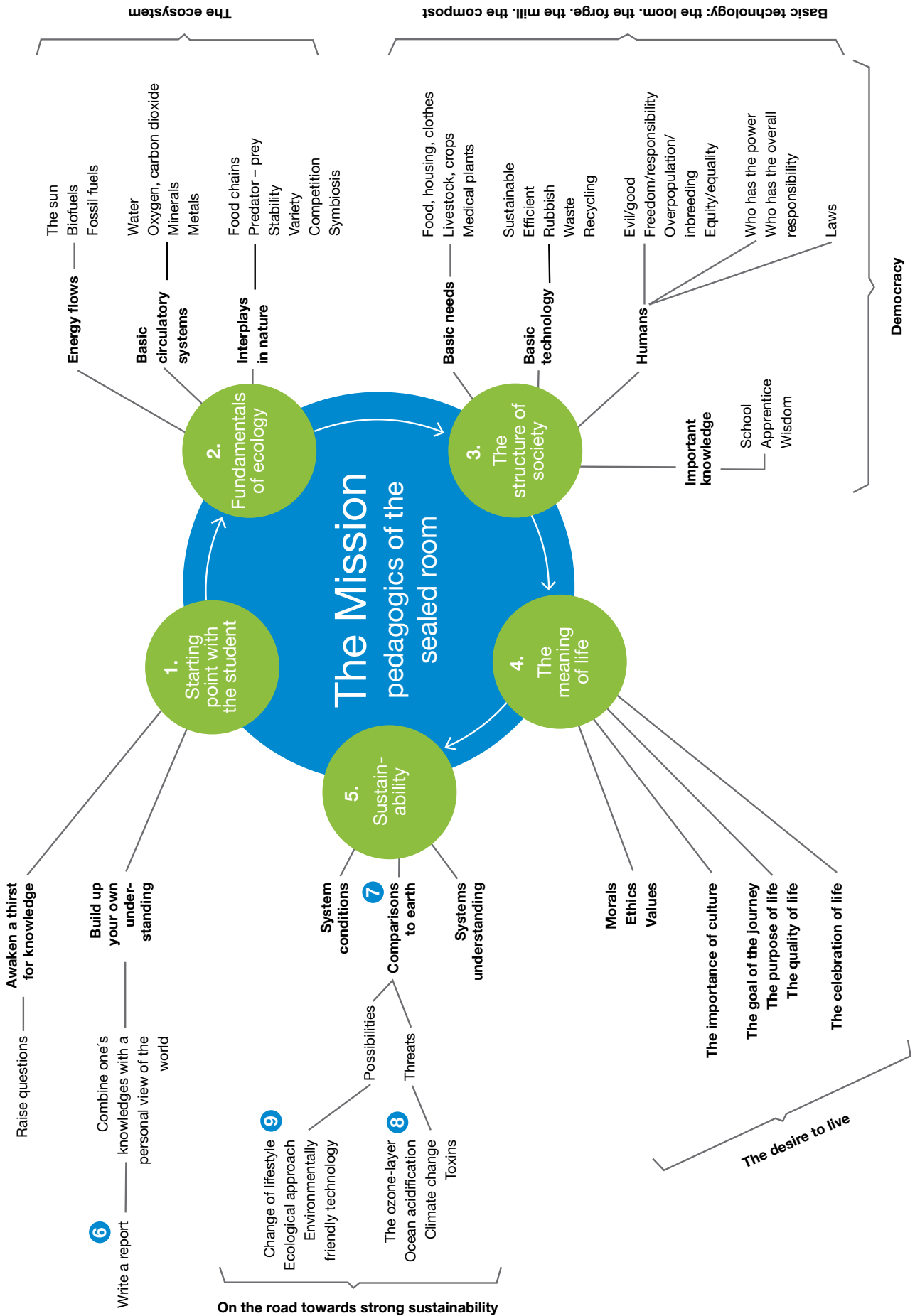



## Objectives

- To raise understanding of the basic prerequisites for a good life.
- To realise that these are dependent on both a sustainable relationship with nature as well as the presence of a fair, equal and democratic society.

Inspired by the Earth Charter Initiative



1.5–5 hours

# A Good Life

## Introduction

It is crucial for the learners to develop the capacity for critical thinking and to raise their awareness and understanding of the connections between environmental, social and economic dimensions in our world. This example is designed to allow the learners to discover some of the prerequisites for a good life. In the process they also will realise that these conditions are dependent on both a sustainable relationship with nature, as well as the presence of a fair, equal and democratic society. Valuable background information and inspiration for this task was provided by The Earth Charter Initiative. ([www.earthcharterinaction.org](http://www.earthcharterinaction.org))

## Working process

Familiarize yourself with the task and make the necessary preparations to assist learners in coping with it. Hand out the worksheet and ensure that they will use it throughout the entire exercise. The work will be done in four steps:

1. The groups explore what “a good life” means for them personally as well as when discussed in small groups.
2. The groups present the outcomes of the group discussions to the whole class in a “plenary session”.
3. The groups revise their findings out from a sustainability perspective.
4. The groups present final conclusions to the class.

### 1 A good life – discussions in small group

- Let the learners start with the first personal assessment (section 1).
- Pair the learners of and let them present their writings to each other. Write down the agreements they have reached after their discussions (section 2).
- Merge two pairs into groups of four and repeat the task in this new grouping (section 3).

### 2 Presentations to the whole class

- Bring all learners together and start a “plenary discussion” on their conclusions. Structure their outcomes under suitable headings such as: *health, security, basic needs, social relations*, etc.
- Discuss unsustainable conditions versus sustainable. Also discuss the economic cost for the conditions to be fulfilled (section 3).

### 3 Sustainable life

- With the input from the plenary session regroup the learners in their original groups of four and ask them to revise their document by considering the following: What must be ...
- removed from
  - added to
  - retained in...
- section 3 in order to achieve sustainability? (section 4).

## 4 Final conclusions

The last step is to link their activities to a bigger picture by bringing in a number of necessary ecosystem services into their discussions. As a final assessment the learners present their findings to the class under the heading: "Some prerequisites for a good and sustainable life". The document from the Earth Charter Initiative can provide valuable background information to these discussions. But there are of course many other sources they can use.

### Worksheet 1

**Holistic  
Examples**  
A Good Life  
**1**  
worksheet

## A Good Life

**1. Condition for a good life**  
Personal assessment

*"What are the most important conditions that have to be fulfilled in order to have a good life?"*

Write down these conditions without discussing with other learners.

.....

.....

.....

.....

**2. Condition for a good life**  
Discussions in pairs

*Form pairs according to the instructions from the teacher.*

- Present your writings to each other;
- Discuss and make new agreements on the task.

*After our discussions we have agreed upon the following:*

.....

.....

.....

.....

**3. Condition for a good life**  
Discussions in groups of four

*Form groups of four according to the instructions from the teacher. Repeat the procedure from section 2.*

*After our discussions we have agreed upon the following:*

.....

.....

.....

.....

**4. Conditions for a sustainable life**  
Discussions in groups of four

*Revised version after the plenary session. What in our section 3 has to be revised, removed, added or retained?*

.....

.....

.....

.....

**5. The bigger picture: Sustainable life and ecosystem services**  
Discussions and work in groups of four

- Give examples of different types of ecosystem services that are necessary for having "a good and sustainable life".
- Summarize your ideas and conclusions and present them in a written document, poster or small exhibit.

# Holistic Examples

Eco-footprint  
Global hectares  
Sustainability  
Fairness

## Objectives

- To understand and use the concepts: eco-footprint, global hectares (gha).
- To reflect on and have ideas about how to influence the eco-footprint in a fair and sustainable way.



2–3 hours

## Necessary equipment

For this task your learners might need computers with a good connection to the internet.

## Valuable link

[www.footprintnetwork.org](http://www.footprintnetwork.org)

[www.footprintnetwork.org/en/index.php/GFN/page/personal\\_footprint/](http://www.footprintnetwork.org/en/index.php/GFN/page/personal_footprint/)

# Ecological Footprint

## Introduction

The ecological footprint is a measure of human demand on the Earth's ecosystems. It represents the amount of biologically productive land and sea area necessary to supply the resources people consume, and to assimilate associated waste. Ecological footprint analysis compares the human demand on nature with the biosphere's ability to regenerate resources and provide services. Ecological footprint analysis is now widely used as a measure of our dependence on nature and an indicator of environmental sustainability (adapted from [www.footprintnetwork.org](http://www.footprintnetwork.org)).

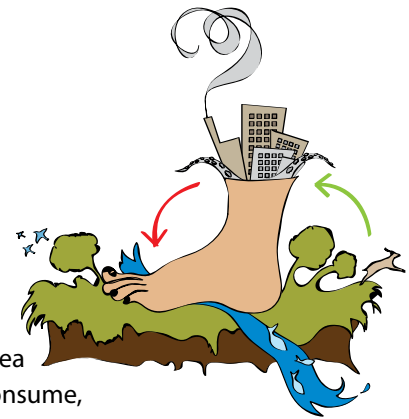

## Working process

The eco-footprint is very useful when discussing environmental sustainability and when making lifestyle comparisons between nations or individuals. It is also quite a complex and advanced tool that calls for solid background knowledge in a number of subject areas. Make sure that your learners have the necessary skills and that they occasionally have access to computers connected to the internet. Prepare copies of the three worksheets needed for this example.

- 1** Introduce the eco-footprint concept and make sure that the learners have a basic understanding of how it is calculated (Worksheet 1). If the learners have access to computers they can calculate their own footprint at: [www.footprintnetwork.org/en/index.php/GFN/page/personal\\_footprint/](http://www.footprintnetwork.org/en/index.php/GFN/page/personal_footprint/)
- 2** Introduce the concept of global hectares as an indicator of how sustainable a certain footprint is from a global perspective. Let the learners compare average footprints from different nations and also discuss trends in the development of the eco-footprints (Worksheet 2).
- 3** When the learners are familiar with the concepts above, it is time to focus on how to find a fair and sustainable way of using the common resources on planet Earth. In this example we use their participation in a hypothetical "International Youth Conference" as a teaser to motivate learners. Divide your learners into groups of 3 or 4 and hand out copies of Worksheet 3. The task the learners are faced with is of course very demanding and complex. Bring it down to their level of understanding and help them to gather necessary background information before formulating their final letter. Actually having classmates of the same age in other countries to send the letters to, will of course engage them and sharpen their arguments.

In their discussions they should try to come up with:

- smart, strong and wise arguments;
- thoughtful or new approaches that might impact on the behavior of young people in other parts of the world;
- limitations of footprints e.g. resilience, biodiversity etc.

The final letter could be addressed to learners or schools within your own country or region, since these types of inequalities exist everywhere. In the end the learners might conclude that the letter also is intended for themselves.

**Holistic Examples Ecological Footprint**  
1  
 worksheet

## Ecological Footprint

Ecological footprint is now widely used around the globe as an indicator of environmental sustainability.

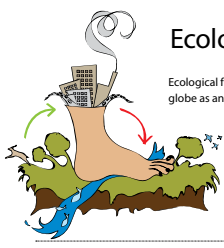

1. What is an ecological footprint? Write down a short definition of the concept.  
 \_\_\_\_\_  
 \_\_\_\_\_
2. The ecological footprint is often divided into sectors according to the main services these areas provide. Look at the illustrations below and give a short description of services we can get from these areas.
  - a. Bioproductive Land \_\_\_\_\_  
 \_\_\_\_\_
  - b. Bioproductive Sea \_\_\_\_\_  
 \_\_\_\_\_
  - c. Energy Land \_\_\_\_\_  
 \_\_\_\_\_
  - d. Built Land \_\_\_\_\_  
 \_\_\_\_\_
  - e. Biodiversity \_\_\_\_\_  
 \_\_\_\_\_

**Holistic Examples Ecological Footprint**  
2  
 worksheet

## Global Hectares and Ecological Footprints of Nations

1. The concept of a global hectare (gha) is a useful tool when we compare the size of the ecological footprint between persons or countries. What is a global hectare?  
 \_\_\_\_\_  
 \_\_\_\_\_

If the global hectares were shared in a fair way between all citizens of the world we would all have access to, in round figures, two global hectares per person (=20.000 m<sup>2</sup> or the size of about four football fields). In fig. 1 you will find figures on the average eco-footprint for different nations. In fig. 2 you can see the trend on how they have developed since 1961. Study the tables.

**Fig 1.**

Country	Population (millions)	Eco-footprint (gha)
Denmark	5	8.3
United States	308	8.0
Sweden	9	5.9
Norway	5	5.6
Germany	82	5.1
United Kingdom	61	4.9
Botswana	2	2.7
South Africa	49	2.3
Available Global hectares	6.7 billion	1.8
Swaziland	1	1.5
Zimbabwe	13	1.3
Lesotho	2	1.1
Angola	18	1.0
Zambia	12	0.9
Mozambique	22	0.8
Dem. Rep. of the Congo	63	0.8
Malawi	14	0.7

**Fig 2. Ecological Footprint per person 1960–2010**

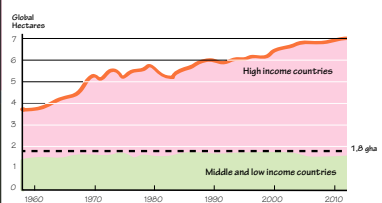

1. Why do countries have different eco-footprints? Give three good reasons.  
 \_\_\_\_\_  
 \_\_\_\_\_  
 \_\_\_\_\_
2. What has happened with the eco-footprint over time? Describe the trend and come up with three good explanations why.  
 \_\_\_\_\_  
 \_\_\_\_\_  
 \_\_\_\_\_

**Holistic Examples Ecological Footprint**  
3  
 worksheet

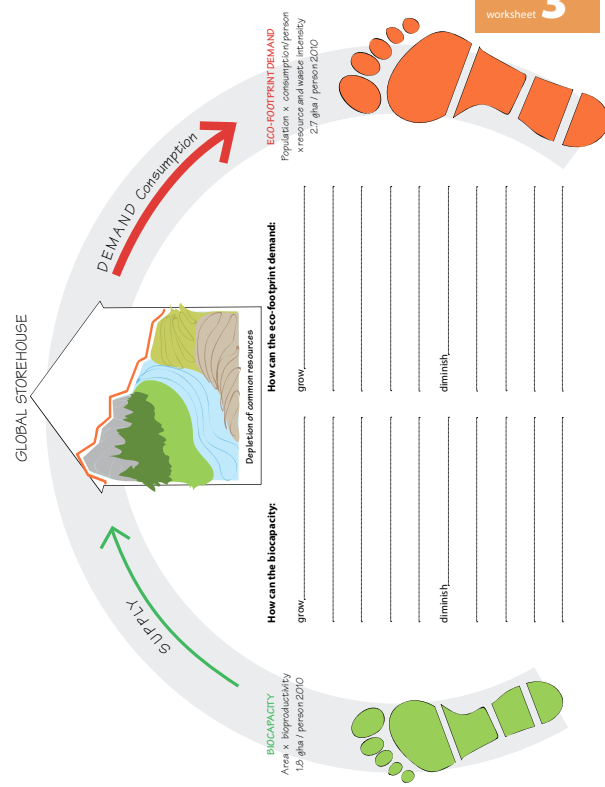

**ECO-FOOTPRINT DEMAND**  
 Population x consumption/person x resource and waste intensity  
 2.7 gha / person 2010

**DEMAND Consumption**

**GLOBAL STOREHOUSE**

**How can the eco-footprint demand:**  
 grow, \_\_\_\_\_, diminish, \_\_\_\_\_

**How can the biocapacity:**  
 grow, \_\_\_\_\_, diminish, \_\_\_\_\_

**BIOCAPACITY**  
 Area x bioproductivity  
 1.8 gha / person 2010

**SUPPLY**

7

**Holistic Examples Ecological Footprint**  
4  
 worksheet

## Eco-footprint and Fairness

**Background**

The size of the personal eco-footprint differs greatly, both within countries and between countries. If fairly distributed every person should have access to approximately two global hectares (gha) each, but in reality we are far from that goal. What could be done in order to reduce these inequalities?





0,7 gha      1,5 gha      10,0 gha

**Task**

You and your class have been selected to represent your country at an International Youth Conference about Lifestyles, eco-footprints and fairness. As preparation for this conference you will work in groups of 3–4 people with the goal of coming up with smart, strong and wise arguments that should influence the choices and lifestyles of young people in other countries.



**Option 1**

You live in a developing country. You have learnt that the ecological footprint of wealthy nations is increasing and is far beyond what is sustainable. Write a letter to learners in a developed country informing them of the consequences of their way of life. Suggest to them sustainable ways of living that could help reduce their ecological footprint.

**Option 2**

You are in a developed country. You have learnt that the ecological footprint of wealthy nations is increasing. Write a letter to learners in a developing country informing them of the consequences of your way of life. Inform them of the choices that you can make and those you have made to reduce your eco-footprint at individual, societal and national levels.

Which sustainability practices would you encourage people in developing countries to maintain in order to keep their eco-footprints small?

# Holistic Examples

Ecosystem dynamics  
Economics  
Game theory  
Ecosystem services

## Objectives

To get a deeper understanding of the challenges in managing common resources and some tools on how to reduce the risks of over-exploitation.



1-1.5 hours

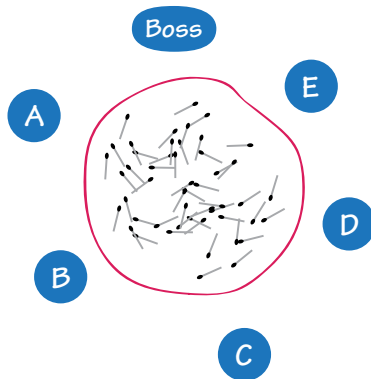

## Necessary equipment

- ⊗ Big match boxes with new matches (200 matches/group)
- ⊗ A3 sheets of paper
- ⊗ Background information on "The tragedy of the commons", adapted to the age group of your learners and on how far into the dilemma you would like your students to go

# The Fish Game

– or how to overcome the tragedy of the commons

## Introduction

In this simple game the learners will get the opportunity to experience some of the driving forces behind a dilemma known as "The tragedy of the commons". According to Harding this dilemma arises from the situation in which multiple individuals, acting independently and rationally consulting their own self-interest, will ultimately deplete a shared limited resource, even when it is clear that it is not in anyone's long-term interest for this to happen (Garret Harding, Science 1968).

The dynamics in the "tragedy example" have been used when explaining a wide variety of examples of over-exploitation of common resources; such as overgrazing, overfishing and also climate change due to unregulated CO<sub>2</sub> emissions.

Lately Nobel Laureate Elinor Ostrom received her prize in Economics due to her research on this dilemma. Ostrom argues that the tragedy of the commons may not be as prevalent nor as difficult to solve as Harding implies, since local people have often come up with solutions to the commons problem themselves; when the commons is taken over by non-local people as Harding suggests, those solutions can no longer be used. Hence, a commons need not be owned by a state or an individual to be sustainably managed. Local communities can solve the "commons problem" if they own the resource together and decide upon common rules.

In this game you will, in a simplified way, have the opportunity to address some of these complex issues. The discussions, of course, have to be adapted to the skills and age group of your learners.

## Working process

Learners play this game twice. In the first the learners probably will deplete their resources quite fast. In the second game they will explore strategies to avoid this "tragedy". It is crucial for the outcomes that the players follow the instructions carefully, especially the condition that *they not are allowed to communicate with each other during the first game!*

Start by playing the game and use the outcomes as an introduction to a deeper discussion on resource management and over-exploitation.

- 1 Distribute **Worksheet 1** to the learners and proceed according to the instructions.
- 2 Compare the outcomes of game 1 and 2 by filling the results in on the table and answer the questions on **Worksheet 2**.
- 3 Use the outcomes of the game as an introduction to a deeper discussion on resource management and over-exploitation.
- 4 Link your work further to local and global examples of the "tragedies of the commons" and let the students discuss possible actions both at a personal, community and governmental level. Develop tasks that suit your age groups or conditions.

**Holistic Examples**  
 The Fish Game  
1  
 worksheet

## The Fish Game

**What is needed**

- A big sheet of white paper where you have drawn the outline of a lake, this will be your play ground.
- A big matchbox with matches representing fish in the lake (at least 200 matches).

**Preparations**

1. Divide into groups with 1 boss and 5 players (A–E).
2. The boss puts 50 matches = 50 tons of fish into the lake and names the players A–E.
3. The participants read the instructions for the first game, and without talking to each other they decide on a personal strategy.

**Game rules first game**

1. One game session consists of 8 rounds.
2. The player (A) who initiates the first round will be the last one in the next round, and so on for 8 rounds. Thus each player has at least one turn to be "first" in a round.
3. You fish by taking matches out of the lake, one player after the other, from A–E. You decide yourself on how big your catch will be during each round, but you have to consider the following conditions:
  - Maximum catch during one round is **6 matches** = 6 tons of fish.
  - The operating costs for boat and equipment are equal to **1 match in each round**, regardless of how big your catch is. This applies even if you haven't had any catch at all! These costs are paid to the boss at the end of each round.
  - At the end of each round the fish population reproduces itself. The rate is that the amount of fish left in the lake will double, but there is an upper limit; the lake cannot feed more than 55 tons of fish at the same time. The boss is responsible for checking that the players follow the rules and is also taking care of the fish-replenishing by adding the right amount of matches each round.
4. During the first game the players are, under no circumstances, allowed to talk to each other or come up with suggestions on how to act.

The winner of the first game is the person who after 8 full rounds has the highest total catch.

**Game rules, second game**

1. This time you are not competing with your group members. Instead you work as a team and compete against other groups in your class. Within your group (the Boss included) you are free to discuss, reach agreements and collaborate as much as you like.
2. Conditions for the second game:
  - Proceed the same way as during the first game, except for instructions in point 1 above.
  - After the 8 rounds there still has to be at least 50 tons of fish in the lake.

The winner is the group who after 8 full rounds has the biggest total catch.

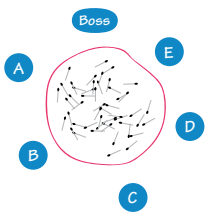

**Holistic Examples**  
 The Fish Game  
2  
 worksheet

## The Fish Game

A. Play the first and second game and fill in the results from each group in the table below

	Group 1	Group 2	Group 3	Group 4	Group 5	Group 6	Group 7	Group 8
First game								
Total catch: Winner								
First game								
Total catch: Our group								
Second game								
Total catch: Our group								

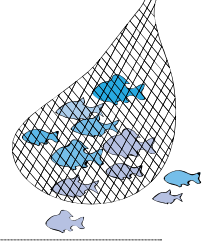

1. Compare the total catch between the first and second game. Why were the results so different? Reflect on the outcome!  
 \_\_\_\_\_  
 \_\_\_\_\_  
 \_\_\_\_\_
2. What is required to manage a common resource?  
 \_\_\_\_\_  
 \_\_\_\_\_  
 \_\_\_\_\_
3. What is the ideal fish population for sustainable fishing?  
 \_\_\_\_\_  
 \_\_\_\_\_
4. When does the population of fish start to deplete?  
 \_\_\_\_\_  
 \_\_\_\_\_  
 \_\_\_\_\_

B. Read about "The tragedy of the commons". Link what you learned from the outcomes of your games to the discussions on "The tragedy of the commons" (for advanced learners Compare Harding's and Ostrom's statements). Discuss in groups or write a short essay.

C. How resilient must the fish populations be to cope with disasters such as an oil spill?  
 \_\_\_\_\_



# Physics

The contribution of Physics to the understanding of strong sustainability is the concept of balance. Physics deals with the balance of energy and matter. Physics states the balance of energy through the first law of thermodynamics: There is a balance between the amount of energy before and after all processes in nature. Energy cannot be created, nor destroyed. The same thing applies for matter. The exception regarding nuclear processes is not important from a sustainability viewpoint. This balance of energy and matter at the atomic level is reflected at higher levels such as an ecosystem or the biosphere. What happens on Earth is that high quality energy (sunrays) reaches the Earth where it gives humans – and life in general – structure, order, and indeed life. But this consumes a lot of energy. In fact, no quality remains as the energy eventually leaves the earth again: when the heat energy has dispersed and cooled down – and there is no temperature difference compared with that of the surroundings – the energy has lost all its quality and it cannot be used.

It's interesting to find these balances in many sustainability issues. There is a balance between the eroding forces in the soil and the rebuilding forces. For fresh water there's the balance between the contamination and the refining processes in nature. In the atmosphere the production of carbon dioxide from animals and man, including technology, must be balanced by the consumption of carbon dioxide by the plants. And for our human society there is the life supporting system that produces resources balanced or not with our rate of consumption.

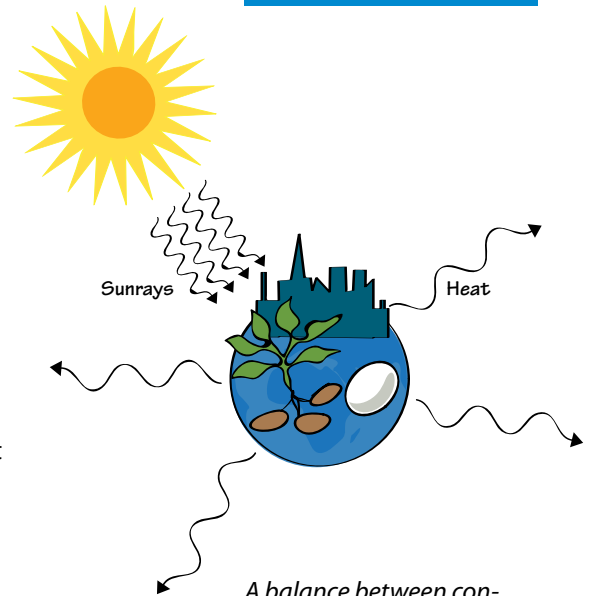

*A balance between consumption and production by nature. The land surface available for every human being on Earth is 2 hectares. That available surface must, without being degraded, produce the resources consumed by one person.*

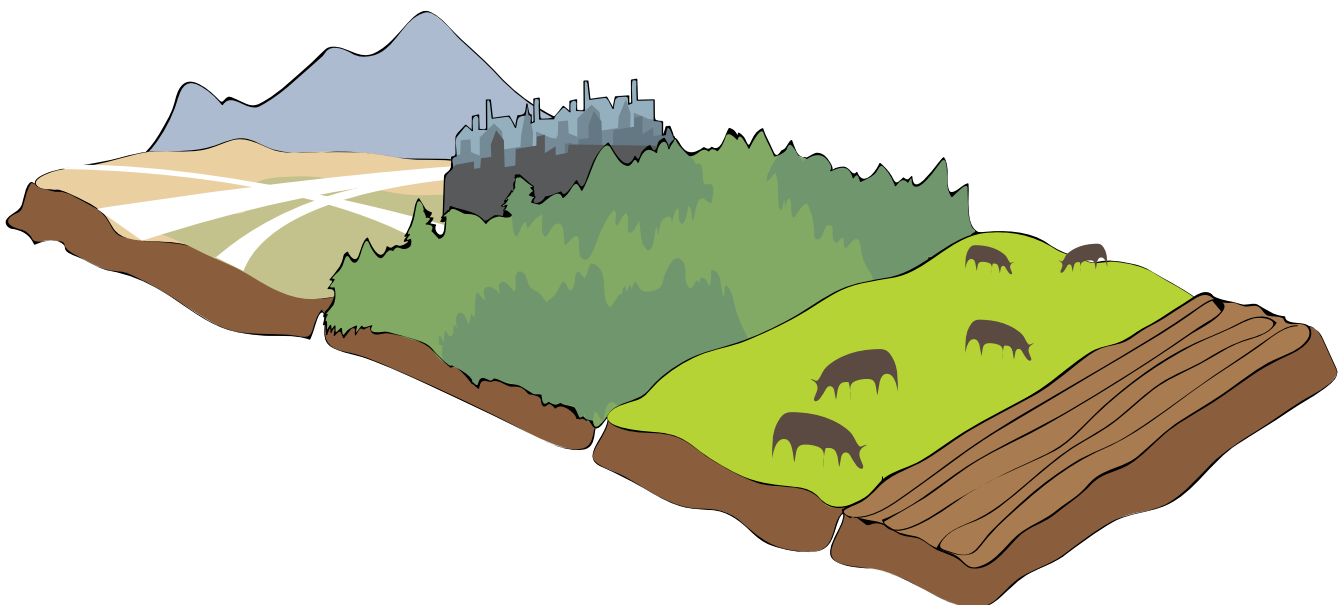



## Objectives

To use information from Physics in order to be able to discuss issues on the greenhouse affect and climate change.



2 hours

## Necessary equipment

(see illustrations on Worksheet 2)

- ☒ Glass flask with cork
- ☒ Heater
- ☒ Thermometer
- ☒ Condenser equipment
- ☒ Beaker
- ☒ Ice cubes  
(see illustration)
- ☒ Copies of 4 worksheets for the learners  
(see attached material)

# Cool News for a Hot Planet

## Introduction

In this example we combine a number of elements from the traditional course in Physics in such a way that they will contribute to the understanding of issues on the greenhouse affect and climate change.

The approach suggested here is the comparison between the temperatures on Earth with the conditions on Venus and Mars. We bring in a number of elements from Physics to explain the delicate balance that makes the climate conditions on our planet so unique as well as facts on greenhouse gases and also on how the presence of life influences the climate. With all this at hand we discuss climate change caused by the impact of human activities such as:

- the impact of increasing carbon dioxide emissions;
- factors that change the albedo of the planet;
- deforestation disrupting climate regulation.



## Working process

- 1 Start with the “planetary approach”** by comparing the conditions on Venus, Earth and Mars (Worksheet 1).
- 2 Demonstrate “the properties of matter”** for water and let the learners become familiar with the concepts that come with it (Worksheet 2).
- 3 Make a short demonstration of the flask with hot water and ice** and use the result as an introduction to the discussion on the external factors that affect the global temperature. Let the learners compile these factors (Worksheet 3).
- 4 Demonstrate “the Albedo” and “the Greenhouse effect”** and let the learners apply what they learn from these demonstrations (Worksheet 4).
- 5 Evaluation.** Instead of an ordinary test you could let your learners write a short essay on: *“How some simple experiments in physics have made me understand issues of the greenhouse affect and climate change”*. To assist them, offer a number of useful concepts from the course to put into their essays.



## Cool News for a Hot Planet

*Three Planets*

**Physics**  
Cool News for  
a Hot Planet

1

worksheet

In the illustration you will find basic facts about the temperature and atmospheric conditions on the planets **Venus, Earth** and **Mars**.

A. Read the facts so that you can compare the planets.

B. Use the information from the illustration and fill in the table below

	VENUS	EARTH	MARS
Average temperature (°C)	.....	.....	.....
CO <sub>2</sub> content in atmosphere (%)	.....	.....	.....
Thickness of atmosphere, use: <u>thin, in between, thick</u>	.....	.....	.....
Distance to sun, use: <u>biggest, in between, smallest</u>	.....	.....	.....

C. In what properties of matter can you find water on these planets, i.e. ice, liquid water, water vapour?

Mars .....

Earth .....

Venus .....

D. Imagine that you land with your spaceship on one of these planets. You put on your space suit, open the door and step out on to the planet. Choose one of the planets and describe what you think you would experience.

.....

.....

.....

.....

E. Compare your text with a person who has chosen a different planet.

## Cool News for a Hot Planet

*Properties of Matter*

**Physics**  
Cool News for  
a Hot Planet

2

worksheet

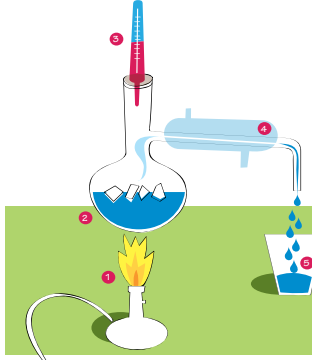

A. Complete the illustration and write down the names of the different parts of the arrangement.

- 1 .....
- 2 .....
- 3 .....
- 4 .....
- 5 .....

B. Describe what happens with the ice during the heating process. Use the words **solid**, **liquid**, **gaseous** when you describe the properties of matter that water may occur in.

.....

.....

C. Complete the illustration.

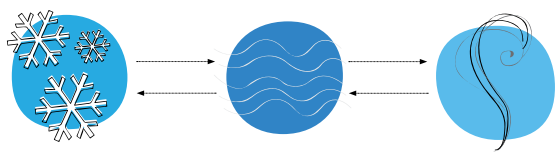

## Cool News for a Hot Planet

*The Flask and The Temperature of the Earth*

**Physics**  
Cool News for  
a Hot Planet

3

worksheet

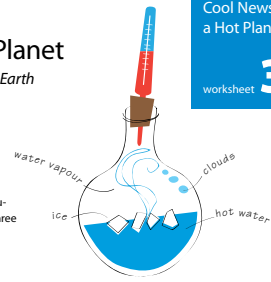

A. The delicate balance

Put hot water in a flask and add a number of ice cubes. For a short period you will have water at all three properties of matter at the same time!

Compare the conditions in the flask with the three planets:

Mars .....

Venus .....

Mother Earth .....

B. What factors influence the temperature and climate of the Earth?

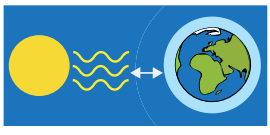

.....

.....

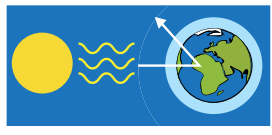

.....

.....



.....

.....



.....

.....

## Cool News for a Hot Planet

*Albedo and Green house effect*

**Physics**  
Cool News for  
a Hot Planet

4

worksheet

.....

.....

.....

.....

.....

.....

.....

.....

.....

.....

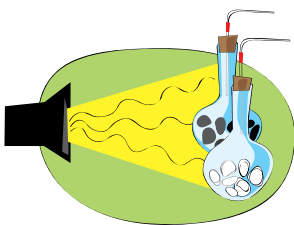

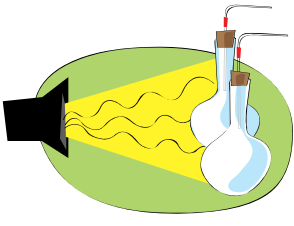

# Physics

Electric circuits and grids  
Energy transformation  
Environmental impacts

## Objectives

- Build a model and apply it to reality.
- Discuss environmental issues in connection to energy production and consumption.



6–8 hours

# The Electric Grid

## Introduction

The energy demand in our society is steadily increasing. Although some regions of the planet remain sparsely populated and have very low energy consumption, many parts of the world are illuminated by billions of light sources connected by steadily growing electric grids. The beautiful picture of the Earth at night by NASA could be viewed as a physical manifestation of that grid. It is also a web or network that connects energy production with our everyday energy consumption. This makes it a perfect pedagogic tool for discussions about:

- existing energy production facilities and their environmental impacts;
- renewable energy production and new smart grids for the transmission and distribution of energy;
- lifestyle, consumption habits and energy saving.



Credit: C. Mayhew & R. Simmon  
(NASA/GSFC), NOAA/ NGDC,  
DMSP Digital Archive.

In this example we approach these complicated and large scale issues by starting at a local and personal level. We let the learners design and build a simple model of the electric grid in a house. (If you don't have time or the equipment for each of the learners to build separate models, you can parcel out the different tasks among groups of learners and have them assemble one or more common models.)

In conjunction with their practical building, we give them basic knowledge about electricity, electrical circuits and how electricity is produced. This approach motivates the learners and creates a desire for knowledge that will facilitate the learning process. In the next step we link their models to reality by introducing simplified local, national or international electric grid systems together with examples on how electricity is produced. In the last step we bring in the environmental dimensions.

### Working process

Prepare yourself by building a personal model of the grid. In this way you will experience the difficulties the learners might run into and what type of tools and knowledge they will ask for. Your model will also function as a demonstration object and facilitate your explanations. Prepare all the practical equipment (Worksheet 1) and figure out how you will blend the learners practical work with appropriate theoretical lessons.

Example of how to connect different components into a simple electric grid

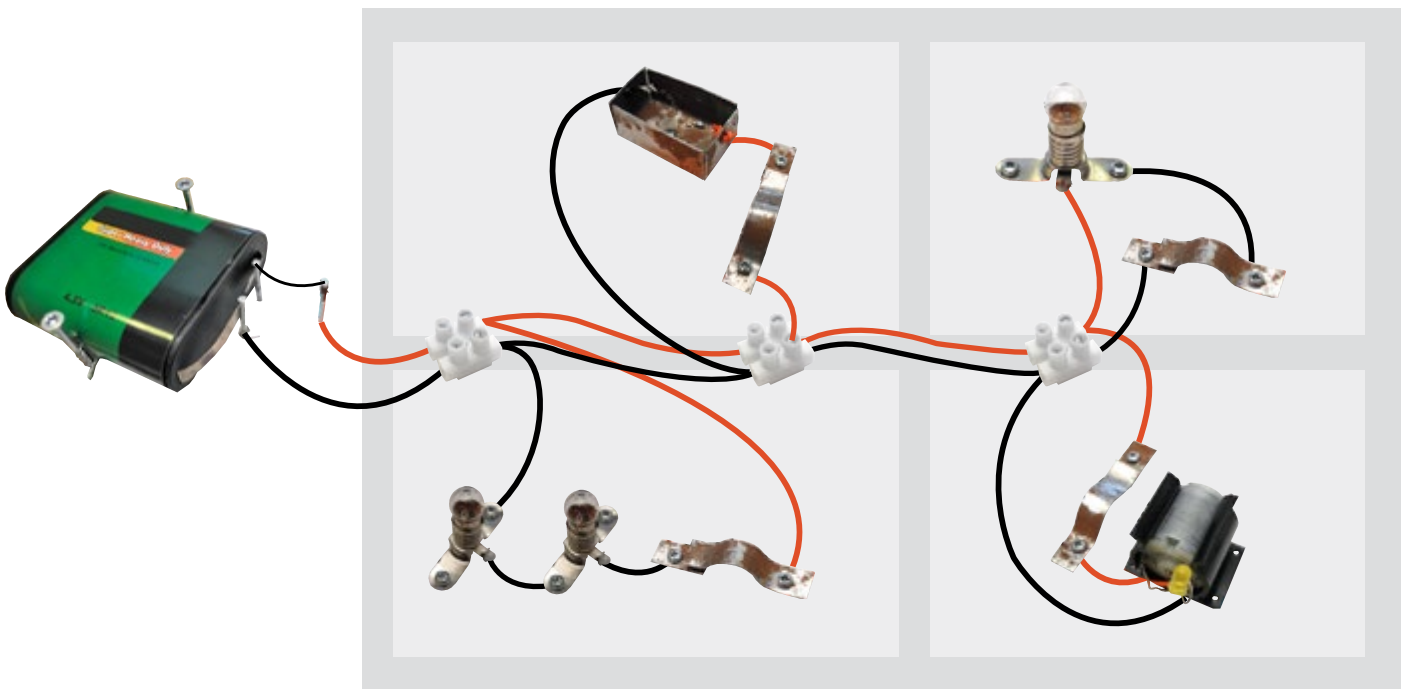

**1 Establish the playground**  
Divide the learners into groups and let them make a simple “architect drawing” of a small house with a number of rooms, using A3 size paper. Let them glue their drawing onto the prepared plywood board and discuss how they would like to electrify their house.

**2 Construction of vital parts**  
Let the learners construct some of the components that later on they will mount onto their model. Provide the necessary equipment and hand out the construction manuals (Worksheets 2 and 3).

**3 Build up the grid**  
If you haven’t covered the subject previously, gradually present the basic elements of electricity, electrical circuits and safety that form part of the course in Physics. Don’t cover too much theory at one time. Let the learners start their assembly work according to the instructions on Worksheet 4. As soon as their practical work begins, they will need more information and you will have eager listeners to all your presentations. Let the learners improvise and build personal grids and allow them to connect different types of objects, for example: lamps and diodes connected in series and parallel, motor, “toaster”, alarm bell, photo voltaic cell and so on.

**4 Testing and learning**  
The learners will automatically learn the importance of properly connected wires. The resistance wire in the “toaster” will become warm but not glow from a 4.5 Volt battery. For that to happen they will need a stronger battery or access to a variable current source. With such a device, we can also demonstrate the function of the fuse:

- I. Connect the variable current source to the nails.
- II. Let the learners turn on all the circuits at the same time.
- III. Increase the current until the toaster glows and in the end the fuse burns off!

You can demonstrate a shortcut in the same way, have discussions about electrical safety and many other elements in the Physics course on electricity.

### Units in a local electric grid

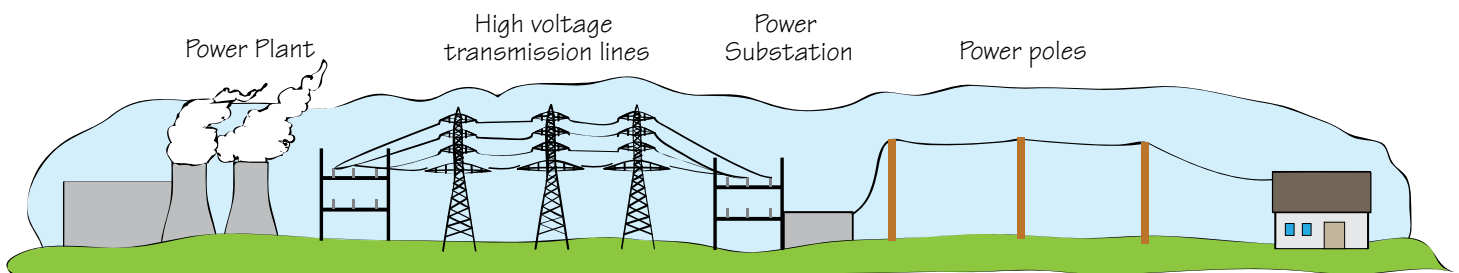

Large scale electric grid with different types of production units and consumers

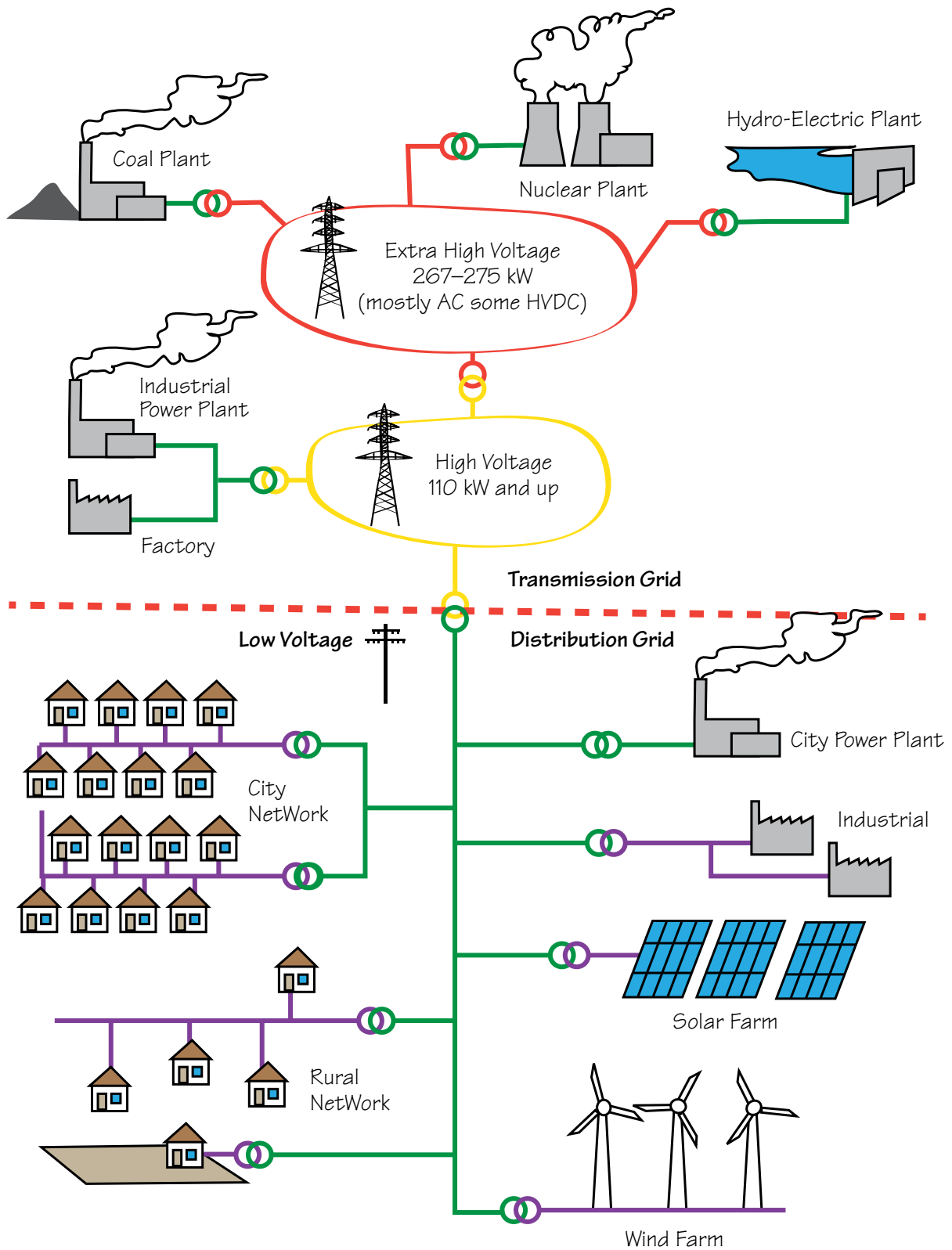

## **5 Applying the model to real life**

When the learners are familiar with the model, take the next step by applying it to real life. Start with a simplified map of a local grid from the region.

- How is the distribution grid organized?
- Where is the electricity produced?
- Think of different ways of producing electricity.
- Why use local diesel/petrol generators?

Widen their focus by presenting national or international grids so that you can also demonstrate different types of production units. Bring in the need for generators, high voltage transmission lines and transformation units. Let the learners make a simplified drawing or a map of “where the electricity comes from when I light up my room or charge my cell phone”.

## **6 Environmental dimensions!**

All the ways of producing electricity have their pros and cons. In some parts of the world the production of electricity is one of the main contributors to raised CO<sub>2</sub> levels and global warming. Give the learners an overview of different methods with a special focus on sustainable electricity production.

Bring in the possibilities of new technical solutions, changed lifestyle and consumption habits. Let the learners summarize their findings in a document, poster exhibition or an oral presentation under the headings:

### **What can...**

- I...
  - our community...
  - private companies...
  - the government...
- do in order to reduce the negative effects of producing electricity?

**Physics**  
 The Electric Grid  
1  
 worksheet

## The Electric Grid

*Tools and other equipment that could be of use*



screw drivers    metal shears    drillers    drill

**To build with and build on**

Thin metal plate for producing the "switches" and the "toaster" (0.5–0.8 mm thick).

Plywood sheet (10 mm thick) on which everything should be installed (size 30x40 cm).

Paper glue.



screws



pliers



lamp sockets



filaments



electric motor



connection boxes



batteries



soldering iron



hammer



electric cables



soldering



resistance wire



alarm bell

**Physics**  
 The Electric Grid  
2  
 worksheet

## The Electric Grid

*Building Electric Switches*

- Draw the external measurements according to the figure and mark where to drill and cut the sheet metal. (If you are making several switches, draw all of them at once next to each other, before cutting and drilling.)
- Make a dent with the hammer and center punch where you are going to make holes. Use a 3 mm drill.
- File off the burr after drilling.
- Use the metal shear to cut the separate switches and cut the sheet metal at the markings. Use a file to smooth sharp corners and edges.
- Bend and shape the long part of the switch into an elastic arm (see pictures).
- Mount the switches and use the same screws to fasten the connecting cables for the different circuits.

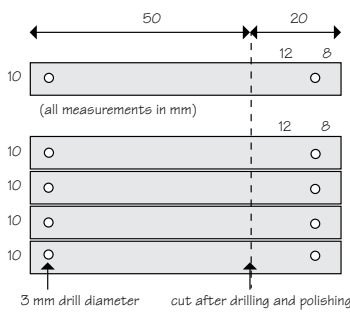

(all measurements in mm)

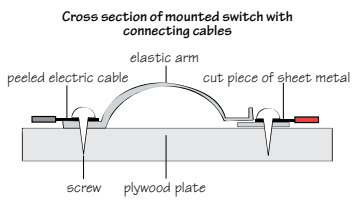

Cross section of mounted switch with connecting cables

**Physics**  
 The Electric Grid  
3  
 worksheet

## The Electric Grid

*Building a Toaster*

**To build a simple model of a toaster**

- Study the blueprint and draw the corresponding measures on the piece of sheet metal provided by your teacher (all the measurements are in mm).
- Drill the holes (diameter 3 mm).
- Cut off the shaded parts and smooth the corners and sharp edges with a file.
- Bend the four flaps so that the sheet metal forms an open box and screw it to the model.

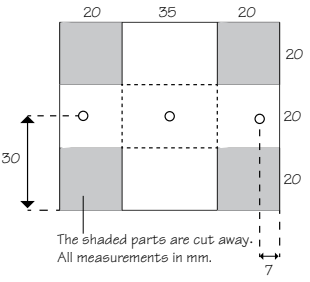

The shaded parts are cut away. All measurements in mm.

**Installation**

- Cut 10 cm of chrome nickel tread (0.4 mm) and wire it tightly around a nail or a very thin screwdriver to make a filament spiral.
- Find suitable connection cables, make a knot at the end of the cable and peel the plastic from 5 mm away.
- Solder the cable ends to the chrome nickel spiral.
- Install the filament spiral inside the toaster by threading the free cable ends from inside. Prevent the soldering and the spiral from coming into contact with the toaster walls.

(If you don't have a soldering iron, twining the cable ends works just as well.)

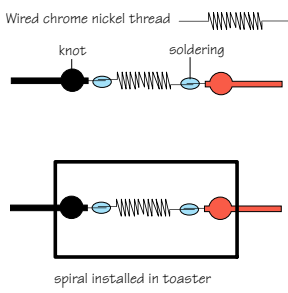

spiral installed in toaster

**Physics**  
 The Electric Grid  
4  
 worksheet

## The Electric Grid

*How to build an electric grid*

- Hammer in two nails where the battery will connect to the electric grid in your model.
- Hammer in a third nail at a distance of 2 cm from one of the battery poles.
- Create a simple "fuse" by connecting this third nail to one of the poles. Use a chrome-nickel resistance wire of 0.4 mm, see illustration below.
- Connect electric cables to the two nails and lay out a main electric line that will reach to all the rooms in your model.
- Put connection boxes where you need connections to the main electric line.
- Connect all the objects to the main line at appropriate positions.
- Make sure that every circuit has its own switch and that the cables are fixed correctly to the plus and minus poles in your grid.

**How to get started**

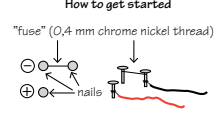

**Beginning of main electric line**

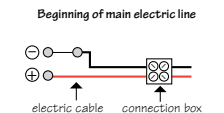
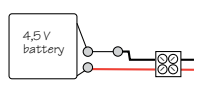
**How to lay the main electric line**

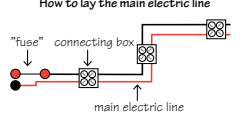

**How to connect circuits to the main electric line**



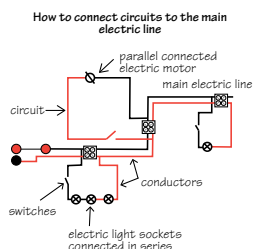

# Physics

Physics – the energy concept, energy is conserved but quality of energy is consumed, heat as random movement of molecules

## Objectives

Learners should demonstrate an understanding that:

- in nature processes happen spontaneously in one way (or “forwards direction”) but never occur spontaneously the other way;
- some of the value of natural resources is used whatever happens in nature;
- the providing of natural resources is dependent on solar energy, often in cooperation with plants – old (fossil fuels) or new (biomass).



2–2.5 hours

## Necessary equipment

- ⊗ Drawing pins or similar items
- ⊗ 2 beakers
- ⊗ Salt
- ⊗ Water
- ⊗ 2 raw eggs
- ⊗ A thin metal bar >30 cm
- ⊗ Vaseline or similar
- ⊗ Candle or bunsen burner
- ⊗ A big box
- ⊗ 10–15 balls that bounce

# Nature Works Forwards

## Introduction

Nature works forwards in the sense that processes always happen in one way, in which natural resources lose their quality. Since we need these resources for everything we want to do, we must choose the right kind and the right amount of resources. Understanding the Second Law of Thermodynamics helps us with this.

## Worksheet 1

### Experiment 1

It is not possible to throw the pins to form a square because of the way nature works. Spontaneously the result of what happens in nature is always disorder. Just think of your room not having been cleaned – disorder follows sooner or later. To create the square of pins or to create order in your room requires energy. Only if you invest time and energy can you carefully place the drawing pins one by one in exactly the pattern you want.

### Possible solutions to the questions

**Question 1:** The second law of thermodynamics could be stated as: *Spontaneous processes create disorder; or Whatever happens, disorder is created; or Matter tends to spread out; or Differences disappear* (in an “attempt” to attain equilibrium).

**Question 2:** More examples of the spontaneous processes in nature are needed to provide deeper understanding of the second law of thermodynamics. In a class discussion, help the pupils to provide examples!

### Experiment 1

**Question 3:** Put an egg in the salt water and show that it floats there, but not in fresh water. (This is the control for confirming the presence of salt in water.)

**Question 4:** Only if you invest energy to boil away the water can you reverse the process and separate the salt from the water.

Having come so far, point out the following to learners: According to this law, the result of what happens in nature is always disorder. If so, how do we have beautiful, orderly things like this egg? (Out of which a living chick can make its way out!)

### Group discussion

Engage with the students and assist them in reaching this important conclusion: It is the action of life which can produce order, but only if sufficient energy is provided. In detail:

- The hen can lay an egg if she eats a lot of seeds (energy).
- The seeds could grow if they get a lot of sunlight (energy).

For example they could find (as illustrated in the introduction to the Physics segment):

1. A potato plant growing from sun, water and nutrients.
2. Buildings form cities built by people using materials and human intelligence.

## Contradiction?

These examples seemingly contradict the second law of thermodynamics. But the order created within a limited space like a city is dependent on the bigger destruction of order outside the limited space. For example the use of fossil fuels, organic matter and so on.

So the second law of thermodynamics is always valid when the bigger picture is considered. In the case of using organic matter we use the disorder created in the sun when sunrays are created through nuclear fusion processes. This is very good for humans, because this disorder is created in the Sun and not on the Earth.

## Worksheet 2. Time for cooking the egg. What happens?

### Experiment 3: The hot bar

*Conclusion:* Pins fall one by one as the conducted heat reaches the vaseline/ margarine. Equally for the boiling of the egg, heat is conducted from the heat source to the pot through the water to the egg.

### Experiment 4. Heat bounces away

Another analogy is to use moving balls as a representation of heat in atomic particles. Prepare a big open box containing 10–15 small balls. One ball is thrown into the box bouncing against the others. All the balls start moving. *Conclusion:* Energy is introduced to the system and it spreads out evenly. Temperature rises in one point, but the heat is spread throughout the system. This experiment is performed in order to help the learners fulfill the last task at Worksheet 3. Solution to the drawing exercise: The learner should draw molecules with the same vibration across the entire metal bar.

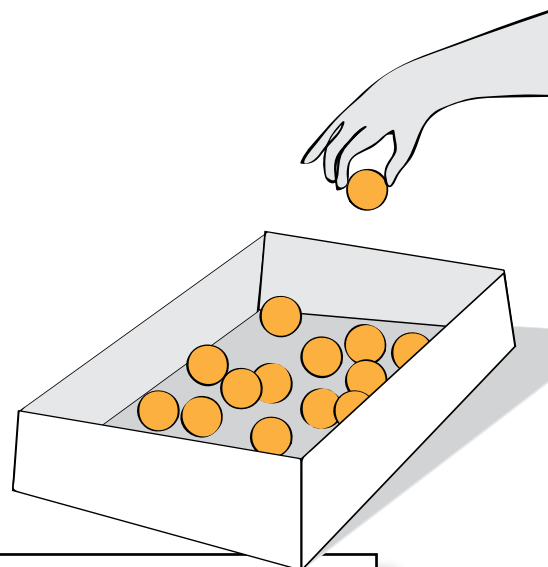

## Heat is the random movement of molecules

This is how the law of nature is predicting. When boiling the egg, heat from the stove tries to spread out, just like the heat from the candle spreads throughout the bar. Energy (heat) is dispersed or spread, but is this disorder? Yes, because heat is actually the movement or vibration of atomic particles in the water or in the

metal rod. The vibration goes in all directions in a random disorder. A high temperature is the lively vibration of atomic particles while the decrease in temperature is the slowing down of the particles' vibration. In the end all molecules move with similar intensity and everything has the same temperature.

**Question 5:** Use the illustration and the suggested answers to the right to assist in the discussion.

To cook the egg there are three different possibilities from the viewpoint of sustainability:

1. *Coal* (a deposit): limited supply, causes imbalances like  $\text{CO}_2$ .
2. *Firewood* (a fund): Acceptable, but overuse is not sustainable.
3. *Solar heating* (a flow): most sustainable option, limited by available surface.

Electricity could be a carrier of energy in all three cases. Electricity is not an energy source, but rather a way of moving the energy to the consumer.

### Deposit

Oil, coal, natural gas, metals (incl. uranium), phosphorus

### Fund

Firewood, fish, food, water dam

### Flow

Sunrays, wind, waves

**Physics**  
 Nature Works  
 Forwards  
1  
 worksheet

## Nature Works Forwards

*Spontaneous Processes*

**Experiment 1**  
 Arrange nine drawing pins in a square and throw another 9 drawing pins into the air. Can you throw these in such a way that they land forming the same pattern of a square?

Yes  No

- State the experience from the experiment as a law of nature.  
 \_\_\_\_\_  
 \_\_\_\_\_
- Find two more examples of this law.  
 \_\_\_\_\_  
 \_\_\_\_\_

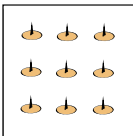

**Experiment 2**  
 Put salt in a beaker of warm water. Stir. Stop when it's not possible to dissolve any more salt.  
 3. How can you show that the salt is there, though invisible?

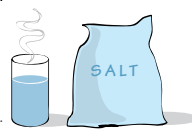

\_\_\_\_\_

- According to the law you just stated, can this be reversed? That is can you remove the salt from the water?  
 Yes  No  Why? \_\_\_\_\_  
 If you answer yes, how? \_\_\_\_\_  
 \_\_\_\_\_

**Group discussion**  
 Find examples of "unspontaneous" processes. This means processes that create order, like with the hen growing because of seeds and the egg out of the hen.  
 Prepare to present the examples for the class.

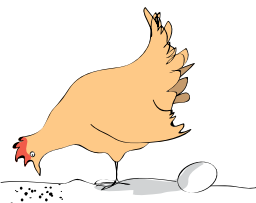

**Physics**  
 Nature Works  
 Forwards  
2  
 worksheet

## Nature Works Forwards

*Cooking the Egg. What Happens?*

If the purpose of the egg is not to be hatched into a chick but to be eaten as a tasty breakfast, it needs boiling. Whatever we want to do, natural resources are needed, in this case of course heat, one form of energy. What is really happening when we boil the egg?

**Experiment 3. The hot bar**  
 Use vaseline to stick the drawing pins to the metal bar. Hold the bar over a candle. Keep the heat on the same end of the bar and wait for the result. In what order do the drawing pins fall and why?

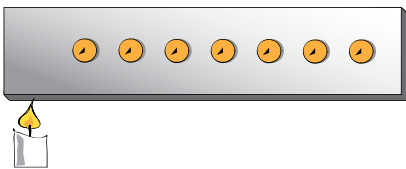

Atomic particles vibrate more on the hot side

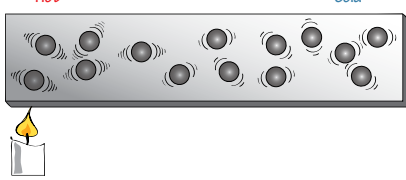

Draw the molecules and show how they vibrate after the candle is taken away but while the bar is still warm:

**Physics**  
 Nature Works  
 Forwards  
3  
 worksheet

## Nature Works Forwards

*The "Best" Way to Boil an Egg*

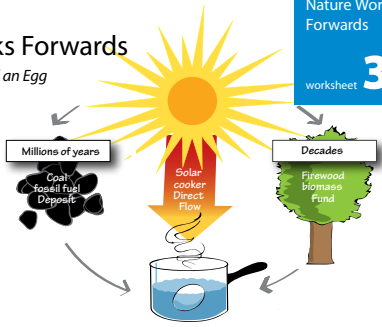

Where does the heat come from?

**Question 5: Which of the three categories do the items in the triangle belong to? Sort them!**

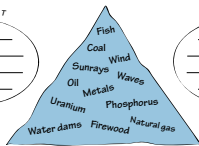
<b>DEPOSIT</b> _____ _____ _____		<b>FUND</b> _____ _____ _____
---	---	--

**FLOW**  
 \_\_\_\_\_  
 \_\_\_\_\_  
 \_\_\_\_\_

**Deposit (non-renewable)**  
 Natural resource stored for millions of years

**Fund (renewable)**  
 Natural resource stored for short time

**Flow (renewable)**  
 Natural resource flowing more or less constantly

**Assessing the sustainability**  
**Three choices for cooking**  
 If you were to grade the above categories in terms of sustainability, how would you grade them?

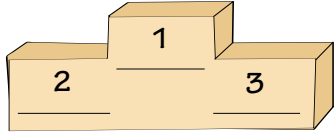



# Chemistry

**H**ow does the subject of Chemistry contribute to a deeper understanding of strong sustainability? Chemistry deals with a basic understanding of the elements that form organic and inorganic realities:

- the different types of elements we have;
- how they react with each other and form new molecules and compounds;
- how they can be separated.

From a sustainability perspective, Chemistry contributes to the realization that we have a finite amount of certain basic elements like metals or nutrients, and that recycling and reusing is the only way to have a continuous supply of them. On the other hand through the study of Chemistry, we also learn that atoms are forever and can never be made to disappear – not even by burning them into the air or burying them in the ground! Chemistry contributes to a more detailed understanding of vital life sustaining processes like photosynthesis, respiration and fermentation. It also connects life sciences to earth sciences and small scale local phenomena to global processes such as the formation of our atmosphere, influences on the climate or the acidification of the oceans.

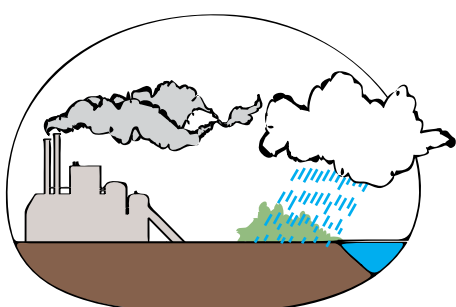

In the example **Acid circumstances**, we connect simple experiments in the laboratory with large scale acidification processes induced by human activities. The learners are inspired to:

- understand the underlying chemistry behind the reactions;
- realize which human activities cause acidification;
- summarize some of the effects shown in nature;
- discuss what could be done to reduce the impacts.

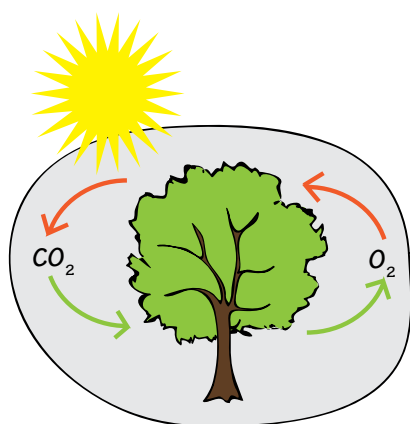

**The Carbon cycle** is an example that touches on a number of big environmental conflict areas. How do we understand and describe the rising  $\text{CO}_2$  levels in the atmosphere? How is it connected to climate change and ocean acidification? What is the difference between using fossil fuels and bio fuels? How is all this connected to our everyday life? The example provides a simplified overview that should help teachers and learners to deal with these issues!

## Objectives

- Understand basic facts about the effects of acidification.
- Connect simple experiments in the laboratory with large scale events in nature.
- Connect lifestyle and consumption to local and global acidification.



2–3 hours

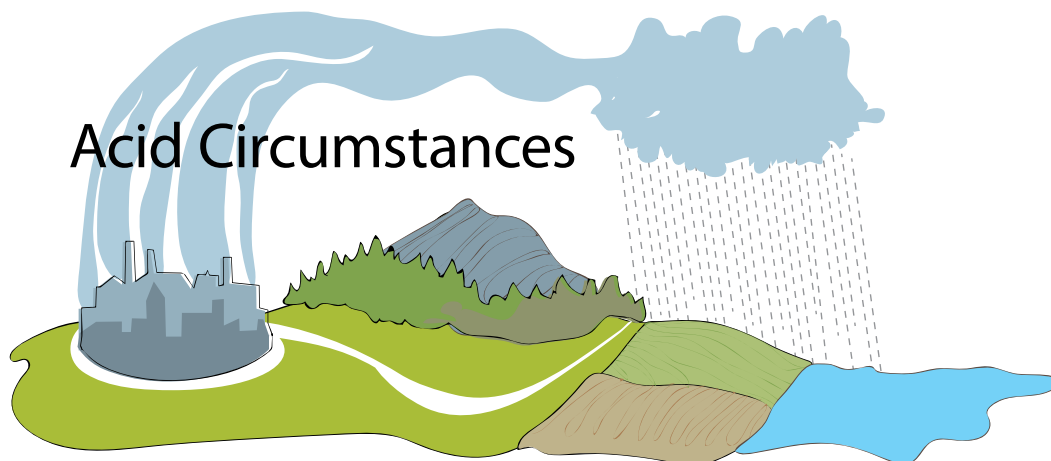

## Acid Circumstances

### Introduction

Acidification of our environment due to human action is not a new phenomenon. By 1882 Angus Smith had already published a book called “Acid Rain”. At that time and for many years thereafter, it was viewed as a severe but mainly local problem occurring in the neighborhood of metal melting factories or big coal burning facilities. In the 1960s, fresh- and groundwater acidification was more geographically widespread and became international problems. Now in the 21st century there are global alarm reports on ocean acidification. Emissions of sulphur dioxide are responsible for 60–70% of the acid deposition that occurs globally. More than 90% of the sulphur in the atmosphere is of human origin. The main sources of sulphur include:

- coal burning;
- melting of metal sulfide ores to obtain the pure metals;
- volcanic eruptions that add sulfur to the atmosphere in a regional area;
- organic decay.

Another big contributor to the acidification are human induced  $\text{CO}_2$  emissions. Over the past 200 years, the oceans have absorbed approximately half of the carbon dioxide ( $\text{CO}_2$ ) emitted by human activities. But absorbing the  $\text{CO}_2$  causes changes in ocean chemistry, producing carbonic acid, lowering pH and decreasing carbonate ion ( $\text{CO}_3^{2-}$ ) concentrations – influencing the calcification process among corals, crustaceans and molluscs. In this example, we will address some of these issues and link them to lifestyle and consumption patterns.

### Working process

1. Prepare the demonstration set up according to part A, Worksheet 1. Use a very small amount of sulphur, since the produced sulphur dioxide gas is very sticky. You might need a burner to make the sulphur catch fire with a very small blue flame. In this instance the running water will suck the  $\text{SO}_2$  gases through the bottles and acidify the water.
2. Let the learners describe the experiment and help them to write simple reaction formulas.
3. Part B of the worksheet they can probably do themselves.
4. The next step is to apply what they just have learned to reality. Worksheet 2 provides an overview of causes and effects of acidification.
5. “An acid day!” Discussions on lifestyles, consumption habits and recycling.
  - Let the learners in groups summarize a number of everyday activities they perform or resources they use.
  - Link these activities to acidification.
  - Come up with suggestions on how to reduce the problems.
  - Present to the class.

### Acid Circumstances

#### *Acidification in the laboratory*

1. Describe how the demonstration set-up is functioning.

\_\_\_\_\_

\_\_\_\_\_

\_\_\_\_\_

\_\_\_\_\_

\_\_\_\_\_

\_\_\_\_\_

\_\_\_\_\_

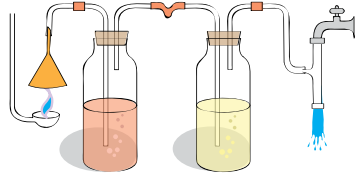

Why is there a colour change in the bottles?  
Use chemical reaction formulas in your explanations.

\_\_\_\_\_

\_\_\_\_\_

\_\_\_\_\_

2. Add two drops of indicator BTB to a baker filled with water. Use the straw and blow your breath slowly into the water. Repeat until you get a colour change.

\_\_\_\_\_

\_\_\_\_\_

\_\_\_\_\_

Why is there a colour change in the beaker?  
Use chemical reaction formulas in your explanations.

\_\_\_\_\_

\_\_\_\_\_

\_\_\_\_\_

\_\_\_\_\_

\_\_\_\_\_

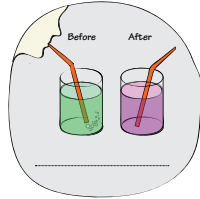

### Acid Circumstances

#### *Acidification in Real Life*

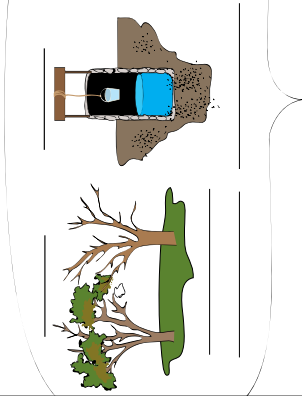
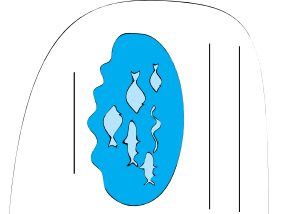
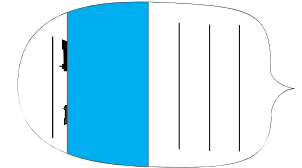
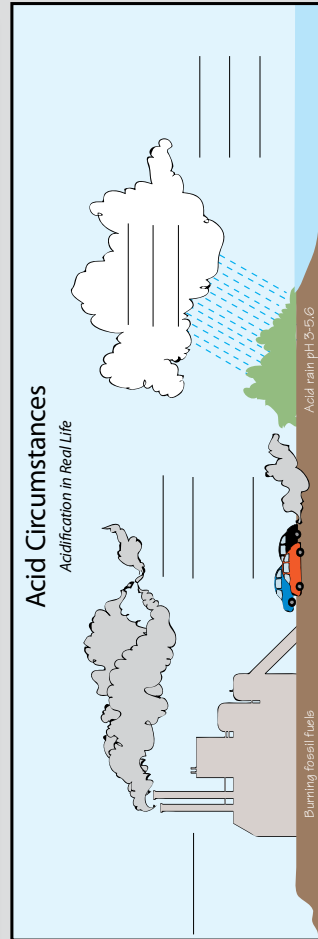

## Objectives

- Understand basic facts about the carbon cycle and how everyday activities feed into it.
- Use the carbon cycle for discussions about climate change and ocean acidification.



2–3 hours

# The Carbon Cycle

## Introduction

A general overview of the carbon cycle is necessary for understanding a number of serious environmental and sustainability problems – from climate change to ocean acidification! Through the carbon cycle we also can connect simple classroom experiments and local every day activities to large scale global conditions and processes. In that way the carbon cycle can form a useful pedagogic tool, provided that we present it at a level where the learners can understand it and contribute to its build up and description. Much of the knowledge base of the carbon cycle is part of different traditional course elements in Biology and Chemistry such as: photosynthesis, respiration, organic chemistry, acids, combustion, burning lime stone, etc. When using the carbon cycle this fact gives us good opportunities to revise and consolidate previous courses and also to build upon them to bring in new perspectives and knowledge. In this example we use a simplified version of the carbon cycle mainly focusing on the time scales of different “tracks” in the cycle and how these tracks are connected to common everyday activities. The examples are very basic but if we are detailed in how they connect to the carbon cycle, they can still serve our purposes in a fruitful way.

## Working process

- 1** Introduce the simplified carbon cycle (Worksheet 1) and let the learners development complete the document. Make sure that they understand the build up of the carbon cycle and that they can use it when connecting the cycle to simple everyday activities.
- 2** By using Worksheet 2 the learners can have more detailed discussions on how photosynthesis and a number of our everyday activities are linked to the tracks 1–3 of the carbon cycle. If it suits your purposes, the introduction of chemical reaction formulas can illustrate the connections to the carbon cycle in a good way.
- 3** The combustion of bio fuel and fossil fuel can be performed as a demonstration (Worksheet 2). Use small porcelain mugs for the fuels and make sure that all vital parameters are exactly the same in the two set ups. Discuss the results and help the learners to connect them to the carbon cycle (track 3–4). Use chemical reaction formulas if possible.
- 4** Ocean acidification is one of the new threats due to increased  $\text{CO}_2$  levels in the atmosphere. Let the learners do the very simple experiment (Worksheet 3) by slowly blowing their breath into a beaker of water containing the indicator. The colour shift will soon be visible. Discuss the results and help the learners to connect them to the carbon cycle. Use chemical reaction formulas if possible.
- 5** As a last step allow the learners to connect the use of fossil fuels with threats to corals and shells in the ocean (track 4–5). In this chain of events there are many interesting chemical reactions to highlight: the chemistry behind the formation of shells and corals; or how acids can dissolve them.

**Chemistry**  
 The Carbon Cycle  
1  
 worksheet

## The Carbon Cycle

A. Complete the document.

B. Describe the different tracks in the carbon cycle and estimate the required time for the carbon atoms to make a full circulation within each track.

Track 1 \_\_\_\_\_

Track 2 \_\_\_\_\_

Track 3 \_\_\_\_\_

Track 4 \_\_\_\_\_

Track 5 \_\_\_\_\_

**Chemistry**  
 The Carbon Cycle  
2  
 worksheet

## The Carbon Cycle

*The flux of Carbon (track 1-3)*

- Describe how the green plants are linked to the carbon cycle.  
 \_\_\_\_\_  
 \_\_\_\_\_  
 \_\_\_\_\_
- Why is it correct to say that the entire carbon cycle is driven by the sun?  
 \_\_\_\_\_  
 \_\_\_\_\_  
 \_\_\_\_\_
- You eat a sweet fruit from a tree and after a while your body has digested it. Describe how this process is part of the carbon cycle.  
 \_\_\_\_\_  
 \_\_\_\_\_  
 \_\_\_\_\_
- Write a simplified chemical reaction formula over the process (sugar = glucose =  $C_6H_{12}O_6$ ).  
 \_\_\_\_\_  
 \_\_\_\_\_  
 \_\_\_\_\_
- You use different types of bio fuels to heat your house and make your food. Describe how the use of bio fuels is connected to the carbon cycle.  
 \_\_\_\_\_  
 \_\_\_\_\_  
 \_\_\_\_\_
- Write a simplified chemical reaction formula of the process (wood = cellulose =  $C_6H_{10}O_5$ ).  
 \_\_\_\_\_  
 \_\_\_\_\_  
 \_\_\_\_\_

Photosynthesis and respiration

$$CO_2 + H_2O \rightarrow C_6H_{12}O_6 + O_2$$

Respiration

Combustion of bio fuels

**Chemistry**  
 The Carbon Cycle  
3  
 worksheet

## The Carbon Cycle

*The flux of Carbon (track 3-5)*

A. Conduct the experiment according to the instructions from your teacher.

- Describe the difference in energy content in the tested fluids.  
 \_\_\_\_\_  
 \_\_\_\_\_  
 \_\_\_\_\_
- Describe the different ways in which ethanol and petrol are connected to the carbon cycle.  
 \_\_\_\_\_  
 \_\_\_\_\_  
 \_\_\_\_\_
- Describe the differences of how the use of ethanol and petrol contribute to increased  $CO_2$  levels in the atmosphere.  
 \_\_\_\_\_  
 \_\_\_\_\_  
 \_\_\_\_\_

B. Conduct the experiment according to the instructions from your teacher.

- Why did the indicator change colour during the experiment?  
 \_\_\_\_\_  
 \_\_\_\_\_  
 \_\_\_\_\_
- Describe how this experiment is connected to the carbon cycle.  
 \_\_\_\_\_  
 \_\_\_\_\_  
 \_\_\_\_\_
- How can the use of fossil fuels infect shells and corals in the ocean?  
 \_\_\_\_\_  
 \_\_\_\_\_  
 \_\_\_\_\_

Combustion of bio fuel and fossil fuel

Carbon cycle and acidification

Ocean acidification





# Biology

**H**ow can the subject of Biology contribute to a deeper understanding of strong sustainability? Biology, as the tale of “the origin of Life and its evolution”, could be viewed as an ongoing drama on how living organisms, both as individuals and in the most astonishing forms of collaboration, under often changing conditions, have found sustainable ways to survive, develop and flourish. Teaching about the richness of this drama and the immense timespan over which it has occurred should fill our learners with wonder, fascination and a deeply rooted feeling of connectedness.



In the example **The Parts and The Whole** we enlarge that investigation and let the learners compare biological systems of different scales. Here they are challenged to find both differences and similarities in these systems and some optimum conditions for their survival. Hopefully all this will strengthen their appreciation of being a part of, connected to, and dependent on nature, both through their basic needs and through their actions.



In the example **What are we Doing With Our Water?** we focus on water as a natural resource and as an absolute prerequisite for life. The learners are inspired to discover water resources and its distribution in the local environment and to observe and discuss the impact of humankind's activities on these resources.

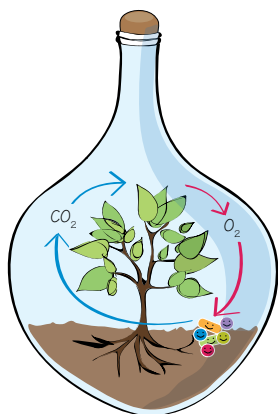

From a sustainability perspective, Biology deals very much with relationships and cooperation, with understanding the small and big systems of which life consists. The example **The Mystery of the Enclosed Garden** is a simplified way to enable the learners to investigate and discuss some of the fundamental relationships in an ecosystem, namely:

- the mutual dependency;
- the “ecosystem services” provided by the partners;
- the absolute need for recycling;
- the “planetary boundaries” represented by physiological tipping points, and symbolically, by the walls of the glass bottle.

# Biology

Systemic approach  
Biosphere and ecosystems  
Life processes  
Boundaries

## Objectives

- Realise that humans are connected to and are parts of natural systems at different levels.
- Understand that there are limitations and boundaries at all system levels.

# The Parts and The Whole

## Introduction

In nature, everything from a single cell to the whole biosphere is vitally linked and closely connected. We are all components of a larger living system through the flow of energy and other resources. When addressing sustainability issues it is essential that we understand that we as human beings are one inseparable part of a greater, complex living system. Our lifestyles and practices affect not only ourselves, but all the other systems of which we are a part. In this example we use a systemic approach where we highlight four system levels within our biosphere.

By using the same approach for each system level we point out the similarities in the processes and conditions for life within these systems. In so doing we illustrate how the simpler parts contribute to the whole and how the whole also creates conditions to favour its parts.

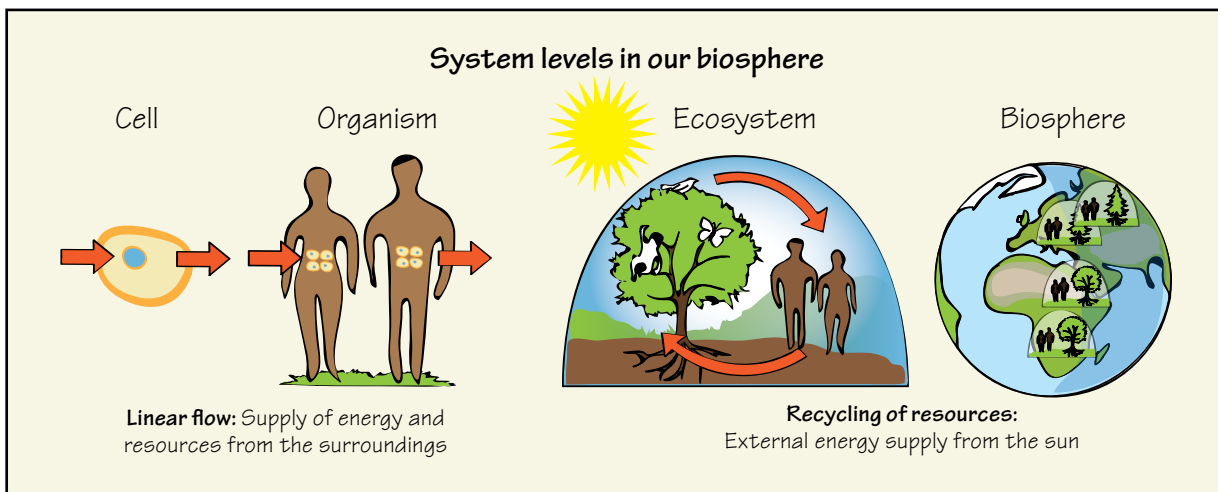

3 hours

## Working process

1. Make copies of the worksheets available to the learners.
2. Introduce the systems approach and describe how we can identify different living systems within our biosphere.
3. Discuss how all systems depend on either a linear or a circular flow of resources.
4. Use the Worksheets 1–3 and let the learners work together in pairs or small groups. Make sure that they understand the similarities between the different systems.
5. Use Worksheet 4 to introduce the concept of system boundaries, with a special focus on “planetary boundaries”.
6. When the learners have become familiar with the introduced concepts and can use a systemic approach when describing relationships between different living systems, it is time for the final assessment:

Imagine you are appointed to represent your school at **the World Youth Forum** on how humans are altering conditions for life on planet Earth.

Prepare a presentation (debate, PowerPoint, poster, newspaper article) on the theme “**we are all connected**” or “**we are part of a whole**”.

**Biology**  
 The Parts and  
 The Whole  
1  
 worksheet

## The Parts and The Whole

The cell is the smallest unit that shows characteristics of life. To stay alive the cell has a metabolism where it takes in energy and resources from the surroundings and excretes different types of waste products. Cells survive by using resources in a linear flow.

- Give examples of resources and waste products that are involved in the life processes of a cell.  
 \_\_\_\_\_  
 \_\_\_\_\_
- Identify five cell types in your body.  
 \_\_\_\_\_  
 \_\_\_\_\_
- Why do you think that there are different cell types in your body?  
 \_\_\_\_\_  
 \_\_\_\_\_
- Give five good examples of how these different cell types contribute to the functioning of the whole organism.  
 \_\_\_\_\_  
 \_\_\_\_\_
- Look at the illustration to the right. Cells within an organism have two different "obligations". Write a short description of the relationship between the cell and the organism.  
 \_\_\_\_\_  
 \_\_\_\_\_

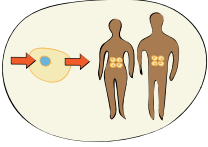

**Biology**  
 The Parts and  
 The Whole  
2  
 worksheet

## The Parts and The Whole

An organism is the smallest functional unit in an ecosystem. To stay alive the organisms have to take in energy and resources from their surroundings and get rid of different types of waste products. Organisms survive by using resources in a linear flow.

- Give examples of resources and waste products that are involved in the life processes of an organism.  
 \_\_\_\_\_  
 \_\_\_\_\_
- Identify five different species that can appear in an ecosystem.  
 \_\_\_\_\_  
 \_\_\_\_\_
- Why do you think that there are different species (high biodiversity) in an ecosystem?  
 \_\_\_\_\_  
 \_\_\_\_\_
- Give five good examples of how these different species contribute to the functioning of the whole ecosystem.  
 \_\_\_\_\_  
 \_\_\_\_\_
- Look at the illustration to the right. Species within an ecosystem have two different "obligations". Write a short description about the relationship between the species and the ecosystem.  
 \_\_\_\_\_  
 \_\_\_\_\_

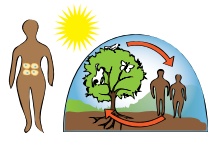

**Biology**  
 The Parts and  
 The Whole  
3  
 worksheet

## The Parts and The Whole

The ecosystem is the smallest functional unit that, with only solar energy, can recycle all the resources it needs. To "stay alive" the ecosystem is dependent on a close cooperation between many different specialized species. Their collaboration has to supply the ecosystem with a sufficient amount of energy and also recycle all necessary resources so efficiently that there will be basically no waste products.

- Give examples of resources and waste products that are involved in the life processes of an ecosystem.  
 \_\_\_\_\_  
 \_\_\_\_\_
- Identify three different ecosystems that can appear in the biosphere.  
 \_\_\_\_\_  
 \_\_\_\_\_
- Why do you think that there are different ecosystems in the biosphere?  
 \_\_\_\_\_  
 \_\_\_\_\_
- Give three good examples of how these different ecosystems contribute to the function of the biosphere.  
 \_\_\_\_\_  
 \_\_\_\_\_
- Look at the illustration to the right. Ecosystems within the biosphere have two different "obligations". Write a short description of the relationship between the ecosystem and the biosphere.  
 \_\_\_\_\_  
 \_\_\_\_\_

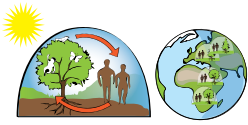

**Biology**  
 The Parts and  
 The Whole  
4  
 worksheet

## The Parts and The Whole

The health and wellbeing of all systems (cellular, organism, ecosystem and biosphere) is dependent upon certain optimal factors. These conditions are termed boundaries and at the global level they have recently been termed planetary boundaries.

- What are the optimal conditions of a cell in the human body?  
 \_\_\_\_\_  
 \_\_\_\_\_
- What are the optimum conditions for a human being for survival?  
 \_\_\_\_\_  
 \_\_\_\_\_
- What are the optimum conditions for sustainability of a natural ecosystem?  
 \_\_\_\_\_  
 \_\_\_\_\_
- What are the optimum conditions for sustaining life on the Earth?  
 \_\_\_\_\_  
 \_\_\_\_\_

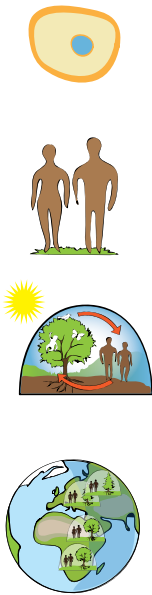

# Biology

Ecology  
Natural Resources  
Interrelationships

## Objectives

- To discover water resources and their distribution in the environment.
- To observe the impact of humankind's activities on water resources.



2 hours for field study and 1.5 hour class periods



Fresh water 1%  
Ice 2%  
Salt water 97%

# What are we Doing With Our Water?

## Introduction

Water in its purest form is a clear, odourless, tasteless liquid. It exists in water bodies, in the soil, in air as vapour, as well as in the form of ice. Water covers more than 70% of the Earth's surface. 97% of this is salt water and the remaining 3% is fresh water. Of this 3% less than 1% is available for life on earth as the rest is in the form of ice at the poles. The growth of the human population and our activities continue to contaminate the little amount of water available for drinking. This makes treatment of water before drinking a necessity. Water supplied by most of the public systems has to be treated with chemicals to remove disease-causing substances and micro-organisms. The contaminants are removed from water by screening, sedimentation, filtration and chlorination or irradiation. Some of the disinfectants and their by-products are potential health risks. Due to the shortage of clean, fresh, flowing water available to treat for drinking, some countries get water from the sea by employing the process of desalination, a process that removes salt from the water.

## Working Process

In this module, the focus is on water as a natural resource.

1. Learners explore the environment around the school and become aware of the natural resources in the area, and specifically water – its sources, distribution, quantity and quality.
2. Learners observe the impacts of human activities on water.
3. Through discussion, students decide on an action they can initiate and carry out to improve the use of water in their own surroundings.

## Exploring the Environment for Water

Prepare students for this field activity through a discussion about natural resources. What are natural resources? Encourage students to name and list them. These will include air, water, soil, plants and animals. Here we will begin with the study of water. (You can then use the same procedure to study the other natural resources in your area.)

## Group Activity

1. Divide students into small groups of 4–6 students each. Each will study a specific aspect of water in a designated area around or close to the school.
2. Give each group a task and question/s that they are to answer by going out and observing the natural environment around the school.

**Biology**  
 What are we Doing With Our Water?  
 worksheet **1**

## What are we Doing With Our Water?

**Water in marriage**  
 In Zulu tradition in South Africa, on the day of her traditional marriage, as one part of the ritual, a maiden is accompanied by a few relatives and friends to the river early in the morning for a bath in the free flowing waters. This bathing marks the end of a period of about three days preceding the ceremony when she stays inside the hut.

1. In what ways do your people use water?
2. Do people in your area still bath and wash in rivers, ponds or other water bodies?
3. Why do people bath in river water or do not bath in it?

**Exploring the Environment for Water**  
**Group 1, Task**  
 Identify the sources and location of water in your study area. Draw a map to show your findings to the rest of the class. Use keys to indicate sources such as faucet/tap, river, pond, wells, puddles, bottles.

**Group 1, Questions**  
 a. Describe what the water looks like.  
 b. In which different forms and colours is it found?  
 c. Where is it located?  
 d. What is its quality and quantity?  
 e. Is it free for everyone? Why or why not?

**Group 2, Task**  
 Identify uses of the water in your study area. Draw a map or poster to share your findings with the rest of the class.

**Group 2, Questions**  
 Where is the water being used as a home for other living things?  
 Where is the water being used to maintain life?  
 Where is the water being used for cooling or heating?  
 Where is the water being used to grow plants?  
 Where did you find the water being used for other things? What are they?

**Group 3, Task**  
 Look for ways in which human activities are having negative or positive impacts on the quantity and/or quality of the water. Draw a map to show the location of these places and clearly indicate which are negative impacts and which are positive.

**Group 3, Questions**  
 1. What human activities did you identify as having a negative effect? Why?  
 2. Which human activities did you identify as having positive effects? Why?  
 3. What are the consequences of these human activities on other human beings?  
 4. What are the consequences of these human activities on other living things?



**Biology**  
 What are we Doing With Our Water?  
 worksheet **2**

## What are we Doing With Our Water?

*Sharing Results*

Working in the same groups as during the previous activity, each group is then asked to take its map, illustrations and notes and complete the following task.

**Task 1: Summarise what you found**  
 Use half the class session for your group to sit together and summarise your findings from the field experience. Describe what you saw? Group 1: sources of water. Group 2: uses of water. Group 3: positive and negative human activities.

\_\_\_\_\_

\_\_\_\_\_

\_\_\_\_\_

What are the most important things that you learnt?

\_\_\_\_\_

\_\_\_\_\_

\_\_\_\_\_

How do your findings affect people in a positive way?

\_\_\_\_\_

\_\_\_\_\_

\_\_\_\_\_

How do your findings affect people in a negative way?

\_\_\_\_\_

\_\_\_\_\_

\_\_\_\_\_

**Task 2: Planning for plenary**  
 Use the second half of the class session to plan a way to present your findings to the whole class. Each group will have a 10 minute presentation and 5 minutes for discussion. All group members should be involved in the presentation in some way. Develop visual aids to make your presentation interesting.



Fresh water 1%  
 Ice 2%  
 Salt water 97%

**Biology**  
 What are we Doing With Our Water?  
 worksheet **3**

## What are we Doing With Our Water?

*Rising to Action: Plenary*

Conserving valuable natural resources, such as water, means that we all need to take action, not only as individuals, but collectively. The challenge for each group is to share the results of their field study in a way that will raise the interest and concern of their audience to the level of wanting to take action to protect the existing natural sources and supplies of water, and to conserve and improve its use.

**Task 1**  
 Starting with Group 1, each Group gives its 10 minute presentation to the whole class, followed by a five minute period for questions and answers.

**Task 2**  
 After all three groups have presented, divide the class into 3 new small groups and give them at least 30 minutes to each identify an action project to be implemented by your class in the study area. Follow the Guidelines below to write an Action Project Plan for your project.

- Title.
- *Introduction:* What is the issue or problem? Provide the information which led you to take action.
- *Objectives:* List at least three things you wish to achieve.
- *Methodology:* List the action steps you will undertake to achieve each objective.
- *Resources:* What resources (manpower, financial, in-kind work, etc.) will you need? (Explain how the class can obtain the needed resources.)
- *Schedule:* Show when each action step will be taken (and who will be responsible for seeing that it is done well and on time).
- *Partnerships:* List possible partners in the community (e.g. a relevant non-governmental organization (NGO) or institution, company or individual).
- *Evaluation:* Explain how your action project will be evaluated and by whom.

**Task 3: Assignment**  
 Each group presents its Action Project Plan. The learners all have an opportunity to question and discuss each of the presented Plans. Learners will summarise the good points and suggest how this could be done to improve the situation. They can then form interest groups and write a letter to the Member of Parliament or local councillor offering their suggestions.

# Biology

Respiration  
Photosynthesis  
Ecology  
Basic circulations  
System dynamics  
Greenhouse effect

## Objectives

- To get an overview on the O<sub>2</sub>/CO<sub>2</sub> balance in small and large ecosystems.
- To suggest what can be done in order to reduce human induced CO<sub>2</sub> emissions.



2–3 hours

## Necessary equipment

- ☒ Glass bottle 1–15 litres
- ☒ Soil
- ☒ Perennial plants with small leaves
- ☒ Spoon
- ☒ Paper tube
- ☒ Long sticks

# The Mystery of the Enclosed Garden

## Introduction

In this example we present a lesson sequence where we use the mini ecosystem within the sealed bottle as a model in order to get a basic understanding of system dynamics and greenhouse gases on Earth.

By enclosing the living actors in a sealed room we challenge the learners' understanding of respiration and photosynthesis. We urge them to examine more closely how the metabolism among living organisms create a dynamic balance of gases in our atmosphere and also what could threaten this balance.

This lesson sequence will also allow us to discuss basic concepts of sustainability such as: CO<sub>2</sub> sinks/sources; ecosystem services and planetary boundaries.

## Working process

Prepare a mini ecosystem according to instruction on page 47 or in the manual you can find on [www.swedesd.se](http://www.swedesd.se).

- 1 Make sure that the learners have a basic background knowledge on respiration and photosynthesis and how these are linked to each other (Worksheet 1).
- 2 Divide the learners into groups and let them come up with a suggestion of the CO<sub>2</sub> content in the bottle over time and the reason for their suggestions.
- 3 Let the learners discuss the driving force and dynamic balance behind the CO<sub>2</sub> fluctuations. If possible, demonstrate these fluctuations with a CO<sub>2</sub> tester or use the graphs in the sheet of suggested answers (Worksheet 2). Use the mini ecosystem in the bottle as a model for your discussions on the atmospheric CO<sub>2</sub> content on planet Earth (Worksheet 2).
- 4 Discuss which processes determine the CO<sub>2</sub> content in our atmosphere and introduce the concepts of "carbon sinks" and "carbon sources" (Worksheet 3).
- 5 Make a connection between the CO<sub>2</sub> content in the atmosphere and the risks arising from climate change. Divide the learners into groups and have them conduct a survey on *how different stakeholders can act in order to reduce their CO<sub>2</sub> emissions*.

### What can...

- our family ...
  - private business ...
  - the municipality ...
  - our government ...
  - the United Nations ...
- do in order to reduce the CO<sub>2</sub> emissions?

Present the results to the class and discuss which measures are the most important ones.

## Instructions on How to Create a Mini Eco System

- 1 Make sure that the bottle is clean.
- 2 Put a sufficient amount of soil into the bottle by using the funnel and the stick. Be careful to ensure that you don't get a lot of soil on the sides of the bottle. It is often good to use fresh planting soil with a high organic content.
- 3 Take the stick and make a small hole in the soil where you wish to plant the plant.
- 4 If the plant is too big to enter the bottle, carefully divide it and compress the soil around its roots.
- 5 Hold the plant by the upper leaves and put the compressed roots inside the bottle. Aim at the prepared hole and drop the plant. Use the sticks to make sure that the roots have sufficient contact with the surrounding soil. Repeat if you want more plants inside.
- 6 When satisfied close the bottle and put it in a place with good light conditions, but not in direct sunshine!
- 7 Usually you don't have to add any water. If after closing you don't see any condensed water inside the bottle it might be necessary to add a small amount.

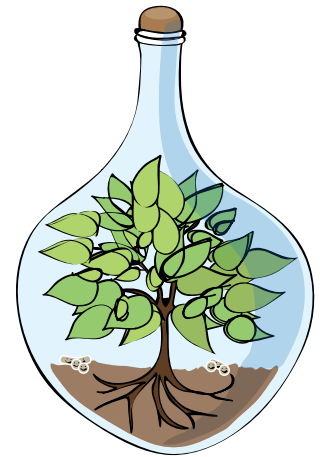

### Maintaining the system

Since the bottle is closed it is very easy to take care of. The most important factor is of course that the system receives enough light without the risk of becoming overheated. That means that you may have to protect it from too much radiation during the summer and add additional light during the dark part of the year. Another factor that sometimes creates difficulties is that you add too much water. We are so accustomed to taking care of our pot plants by watering them once or twice a week that we tend to give the plants in our bottle too much water from start. Usually the moisture in the soil is enough, because metabolic water is emitted as the bacteria begin to decompose the organic material in the soil.

### Self organisation

Besides light and water the system takes care of itself. Of course no single species can manage to live by itself in a sealed room. After a while it becomes obvious to the learners that there are and must be a number of species inside the bottle: plants, different bacteria, fungi, algae, small insects, and so on – and also that they work together in order to maintain the circulation of the life-essential substances within the bottle. The system takes care of itself and develops through self organisation! Small ecosystems with just a few interacting species are of course very fragile. In spite of this even small bottles can survive and flourish for years. There are many secrets behind that fact and in this we have a rich field of biological and chemical phenomena that we can discuss together with our learners.



## The Mystery of the Enclosed Garden

— how can it survive?

**Recycling is the solution**  
C. Recycling  
How is it done and by whom?

**Biology**  
The Mystery of the Enclosed Garden  
worksheet **1**

---

**Cooperation is the secret**  
A. Describe and explain how plants and bacteria depend on each other.

**Biology**  
The Mystery of the Enclosed Garden  
worksheet **1**

---

**B. Your waste is my resource!**  
Describe and explain!

**Biology**  
The Mystery of the Enclosed Garden  
worksheet **1**

---

**Recycling is the solution**  
C. Recycling  
How is it done and by whom?

**Biology**  
The Mystery of the Enclosed Garden  
worksheet **1**

## The Mystery of the Enclosed Garden

The Breath of Life

If you measure the amount of CO<sub>2</sub> in the bottle and in the atmosphere over time you will find both similarities and differences.

**A. Describe and explain the fluctuations of the CO<sub>2</sub> content in the bottle.**  
- Why is the curve fluctuating?  
- What happens to the plant when the amount of CO<sub>2</sub> goes down to zero?

**Biology**  
The Mystery of the Enclosed Garden  
worksheet **2**

---

**B. Describe and explain the fluctuations of the CO<sub>2</sub> content in the atmosphere.**  
- Why is there a rising trend in the curves?  
- Why is there an annual cycle?

**Biology**  
The Mystery of the Enclosed Garden  
worksheet **2**

## The Mystery of the Enclosed Garden

The Balance of Carbon Dioxide in the Atmosphere

**A. Explain how carbon dioxide is removed from our atmosphere (carbon sinks).**

**Biology**  
The Mystery of the Enclosed Garden  
worksheet **3**

---

**B. Explain how carbon dioxide is released into the atmosphere (carbon sources).**

**Biology**  
The Mystery of the Enclosed Garden  
worksheet **3**

# Geography

The Geography lesson examples in this publication reflect the interdisciplinary nature of the subject or learning area. The examples contribute to the understanding of ecosystem services, strong sustainability and agency by emphasizing applications to real life situations that connect with the learners' daily experiences. The examples also bring out linkages to different Geography topics which deal with the use of life-sustaining resources, referred to as the "commons", as well as linkages to related subjects such as Physics. They contribute towards a deeper understanding of planetary boundaries and human-induced calamities such as bush fires.

The examples use the systems approach to highlight the holistic picture of sustainability. The three worksheets promote critical thinking by the individual and groups of learners, draw responses from the learners' diverse contexts and provide opportunities for alternative possible solutions which enable action-taking for sustainability.



### The Bee-Keeper's Story

People living together must find some way to preserve common resources. Unfortunately, there are sometimes strong incentives for people to over-exploit these resources when they are held in common by everyone.

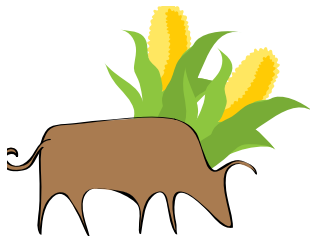

### The Happy Planet

The exercise discusses potential solutions to the problem of common ownership of resources.

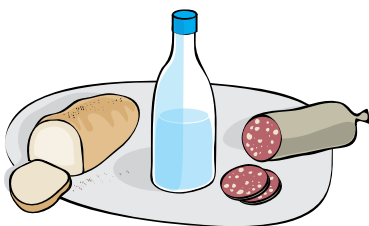

### The Story of the Invisible Water

Possible causes of doom are balanced with opportunities for restoration and how adaptation helps to create resilient systems.

## Objectives

The lesson helps learners to deal with complex issues of social disagreements around common goods and their sustainability.



1.5–2 hours

# The Bee-Keeper's Story

## Who Owns the Bees?

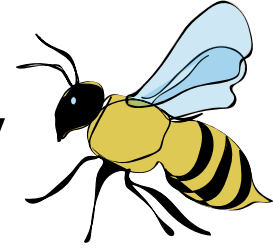

## Introduction

The lesson is based on a life story from Zimbabwe. The lesson uses a bee keeping story with the aim of combining the critical inquiry and problem solving methods to enable competence for sustainability and encourages agency in learners to take action. The lesson helps learners to deal with complex issues of social disagreements around common goods and their sustainability. Most importantly it helps them to think critically about how to deal with others who have no interest in promoting a sustainable way of life and challenges them to use this community setting to explain complex issues in the larger society.

## Worksheet 1

### Individual and group tasks

1. Ask individual learners to write answers to the questions listed.
2. They will then discuss their answers in groups of four, and write their summary on flip charts.

## Worksheet 2

### Discuss the community member who burnt the bees

1. Learners must use the guidelines given to show conflict resolution. They can use a flow chart or other means to illustrate their solution.

## Worksheet 3

### Assignment

1. Using other ecosystem services, how can they apply this story to new situations in our society?

**Geography**  
 The Bee-Keeper's Story  
1  
 worksheet

## The Bee-Keeper's Story



In 2008 two Zimbabweans, Mr and Mrs Shumba, returned from the bank carrying a bag full of money, Z\$ 5 trillion in total. They had failed to buy maize-meal, sugar or cooking oil for the family as the foodstuffs were not available on the market. As Mr Shumba sat down and pondered what to do for his family, he remembered how his grandfather used to sustain his large family with honey from the African wild bees. Mr Shumba then made a decision to set up a bee-hive.

He was helped by Mr. Hove to make a hive using locally available resources. Mr Hove also asked for a bottle of honey, in return for his services and not money. After a while a swarm of bees had settled in the hive and before long, Mr Shumba managed to harvest the honey for his family. He relied on the harvesting skills which his grandfather had taught him. He used some herbs which he burnt to make the bees drowsy during harvesting. In addition to the honey, the community also noticed that an edible berry shrub which had not produced fruit for a long time was now full of berries and more bird species could now be seen in the area. At the beginning of the next rainy season, two other varieties of berries and other small fruits returned. Children could be seen chasing a variety of colourful butterflies which they had not seen before. The community also noticed that many children no longer suffered from frequent bouts of colds and coughs as in the past.

As the demand for honey increased Mr Shumba set up two more hives and started selling the surplus. He could now pay school fees for his children. One day he went to the city to seek market opportunities. The following morning his wife phoned him to say that all the bee-hives had been burnt as someone from the community had tried to harvest honey illegally. Mr Shumba was devastated by the loss and boarded the next bus to return home. As he sat in the bus on his long journey back home, he made up his mind that he was going to re-start the bee-keeping project and started planning the new strategies he was going to use to ensure the future sustainability of the project.

**Whose bees were they?**  
 Discuss the ownership and benefits of the bees.  
 As individuals learners write answers to the following questions:

1. What issues in the life story captured your attention?
2. Where do you think the bees came from?
3. Who is the owner of these bees?
4. What benefits did the bees provide to Mr Shumba and the environment?
5. Make a list of some developments in this local community as a result of the bee-keeping.
6. How much do you think the bees are worth in economic terms? And to whom?

In groups of four, discuss your answers and write your summary on flip charts. You should be able to group the issues into ecological, social and economic benefits

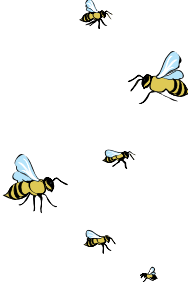

**Geography**  
 The Bee-Keeper's Story  
2  
 worksheet

## The Bee-Keeper's Story

**What went wrong?**  
 Discuss the following questions in groups of four.

1. Why do you think the neighbour burnt the bees?
2. How do you think the neighbour should be treated if he gets caught?
3. How did burning the bees affect Mr Sumba's family, the community, the illegal harvester and the natural environment?
4. Why do you think Mr Shumba felt encouraged to go home and re-start the bee-keeping project?
5. Suggest new strategies for Mr Shumba. How can we use this to build a sustainable community?

As a group suggest a community plan for sustainable bee-keeping. Present your plan to the class and display it on a flip chart.

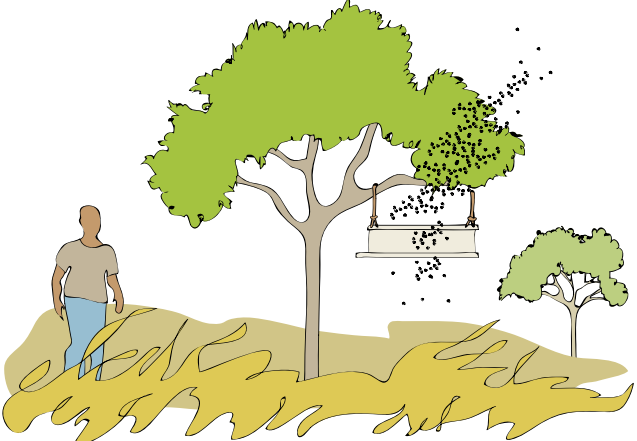

**Geography**  
 The Bee-Keeper's Story  
3  
 worksheet

## The Bee-Keeper's Story

**Assignment**  
 In groups of four, show how we can deal with community misunderstandings about the environment.

Using examples from other ecosystem services:

- How could you apply the strategies discussed above to new situations in our society today?
- How can the management of an ecosystem service support sustainable community livelihoods?

You will need to do more research for this exercise. Present your work on a flip chart, as a poster or write an essay.

## Objectives

- To identify the common, life-sustaining resources and ecosystem services.
- To demonstrate the inter-linkages between social and ecological services.
- To explain how local activities contribute to global climate change.
- To highlight practices that promote sustainable use of resources.



2–2.5 hours

## Necessary equipment

Local environment as learning laboratory.

# The Happy Planet

## – Returning from the Tragedy of the Commons

### Introduction

In this example, we make use of practical sensory experiences of the local environment. This helps to deepen the learners' realization that the life-sustaining elements on Earth, such as our water, the air we breathe, the land on which we grow our food and extract raw materials for our economic development, are non-renewable resources that are common to all of us, regardless of which part of the world we live in.

### Working Process

Learners should be helped to reflect on the life-sustaining resources which they need and use everyday at home or at school on the local level. They need to understand that even if one travels within the region or globally, the basic life-sustaining resources are the same. However, through different economic and social activities, most resources have been severely depleted. They can be restored if people change their practices and consumption patterns. These practices can help create systems which can adapt to change. This is termed resilience. The following worksheets will help learners to develop an in-depth understanding of the vital concepts of the personal, local and global commons, ecosystem services, planetary boundaries or limits, and resilience.

### Worksheet 1

#### Discovering my personal needs for survival

An outdoor activity in which learners take note of what they see, smell, hear or feel around them. Learners should list them and explain why they need resources such as fresh air, water, energy and food on a daily basis. They need to discuss whether these needs are different in other parts of the world and who owns these resources at the local or global levels.

### Worksheet 2

#### Understanding Ecosystem Services and Planetary Boundaries

Models of "me and my personal needs in a bottle" and the "Earth in a bottle" can be used to help explain planetary boundaries. Learners can discuss threats to the commons using the given photographs.

### Worksheet 3

#### What can you do to improve the situation including climate change?

This helps learners to engage in practices that promote sustainable use of resources, as individuals, as a class, as a family or as community members, thus promoting agency and strong sustainability.

### Worksheet 4

#### Hope and engagement

Worksheet 4 highlights stories and activities that can create hope and engagement among the learners. Use the worksheet to inspire them to take action.

**Geography**  
 The Happy Planet  
 Planet  
1  
 worksheet

## The Happy Planet

*Personal Needs for Survival*

**Activity 1**

Go outside the classroom and think about what you used this morning to keep you alive, with the help of what you see, hear, smell or feel around you. List down these vital resources.

.....

.....



.....



In pairs, select and list four resources from the above list which you agree to be the most critical ones for you to survive and for each resource, explain what you need it for in your life.

1 ..... 2 .....

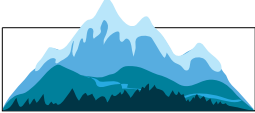
3 ..... 4 .....

Identify the common, life-sustaining resources in different places using the following pictures.

Who do you think is the owner of these life-sustaining resources?

.....

.....

These are some of the life-sustaining resources, also referred to as "the global commons". They come from nature and provide non-negotiable "ecosystem services".

**Geography**  
 The Happy Planet  
 Planet  
2  
 worksheet

## The Happy Planet

*Understanding Personal Boundaries*

**Activity 2**

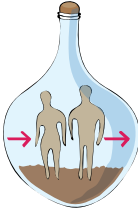
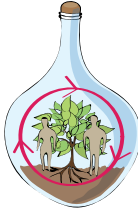



A. Linear flow
B. Recycling

Explain what you think may happen to an individual in each bottle in terms of the life-supporting systems such as:



Water: .....



Air: .....



Food: .....



Energy: .....

Your responses show that there are limits or boundaries as to what can be reached in the usage of these available resources at a local scale.

**Geography**  
 The Happy Planet  
 Planet  
3  
 worksheet

**Activity 3**

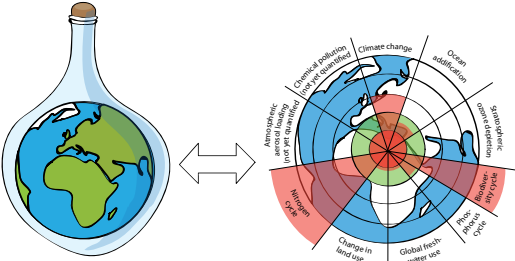

If the Earth was put in a bottle, the red segments show the boundaries we have already surpassed.

Suggest some of the social and economic activities that have led to the development of the situations in the red segments:

Biodiversity loss: .....

.....

.....

Climate change: .....

.....

.....

Nitrogen loading: .....

.....

.....

**Geography**  
 The Happy Planet  
 Planet  
4  
 worksheet

## The Happy Planet

**Activity 4**

Read the following evidence-based story which inspires hope.

**Beyond Deforestation – Restoring Forests and Ecosystem Services**

Despite continued forest conversion and degradation, forest cover is increasing in many countries across the globe. New forests are regenerating on former agricultural land, and forest plantations are being established for commercial and restoration purposes. Plantations and restored forests can improve ecosystem services and enhance biodiversity conservation, but will not match the composition and structure of the original forest cover. Approaches to restoring forest ecosystems depend strongly on levels of forest and soil degradation, residual vegetation, and desired restoration outcomes. Opportunities abound to combine ambitious forest restoration and regeneration goals with sustainable rural livelihoods and community participation. New forests will require adaptive management as dynamic, resilient systems that can withstand stresses of climate change, habitat fragmentation, and other anthropogenic effects.

Source: Chadson, R.L. 2008. In [www.sciencemag.org/content/320/S882/1458](http://www.sciencemag.org/content/320/S882/1458)

There has also been a remarkable reduction in ozone layer depletion, which shows that it is possible to restore the life-sustaining systems and ecosystem services.

Explain how the ozone layer is being restored. ....

.....

Suggest how you as an individual, your school, family or community can reduce biodiversity loss. ....

.....

**Other activities we can do in our communities as part of our commitment to taking environmental action**

The following are highlights of how some communities have engaged in practices that have reversed the tragedy of the commons to a healthy, life-sustaining planet. A series of 12 Handprint booklets has been developed through the CAPE Capacity Development Programme as a resource for educationists to guide Action Towards Sustainability. Copies of the booklets can be obtained through ShareNet and they cover a range of topics which include: Re-using shower and bath water, Bees, Carbon Sequestration, Greens, Invasives, Springs, Disappearing river, Garden Design, Waste, Worming, Mother-tree-Seedlings and Rooibos. These can also be downloaded from [www.capeaction.org.za](http://www.capeaction.org.za).

**Activity 5**

As learners, you can ask your teacher to help you start engaging in school-based environmental projects as guided by the Hand-Prints series or any other projects appropriate to your school situation. You could initiate the project as a class, but it could gradually become a whole school activity to demonstrate strong sustainability and agency.

## The Story of the Invisible Water

### Objectives

- To understand the concept of virtual water.
- To appreciate water as an ecosystem service.
- To understand the necessity of not using more fresh water than nature produces.



3 hours

### Introduction

The water resources on planet Earth are under pressure. There is a strong demand for achieving better management of the common water resources. In order to highlight these issues Professor Arjen Y. Hoekstra from The Netherlands has created the water footprint concept. He says:

“The interest in the water footprint is rooted in the recognition that human impacts on freshwater systems can ultimately be linked to human consumption, and that issues like water shortages and pollution can be better understood and addressed by considering production and supply chains as a whole. Water problems are often closely tied to the structure of the global economy. Many countries have significantly externalised their water footprint, importing water-intensive goods from elsewhere.”

Many of these new perspectives are complex and difficult for the learners to grasp. In this example we will address some of these issues by using a story that can capture the fantasy and imagination of the learners. The story could be told by the teacher or played out in a drama. In this example the roles are to be read by the learners.

### Working process

The short story will be performed by two actors. The actors could be given the text in advance to practice, but the listeners should have a firsthand experience of the text. The story will be interrupted a number of times by different tasks given to the listeners.

#### 1 Water content (I)

As a preparation before the story begins, the learners will guess the water content in a number of objects (Worksheet 2, Exercise 1). Discuss their answers briefly and make sure that the learners have the necessary pre-understanding of vital concepts.

#### 2 First part of the story Your daily water

After the first part of the story the discussion on Worksheet 2, Exercise 2 will help the learners to get an overview of their own daily water consumption.

#### 3 Second part of the story Water content (II)

After having heard the second part of the story it is time to go back to the question from Exercise 1. The learners will discuss their new views on the water content. They will come up with new arguments and write down their statements (Worksheet 2, Exercise 3).

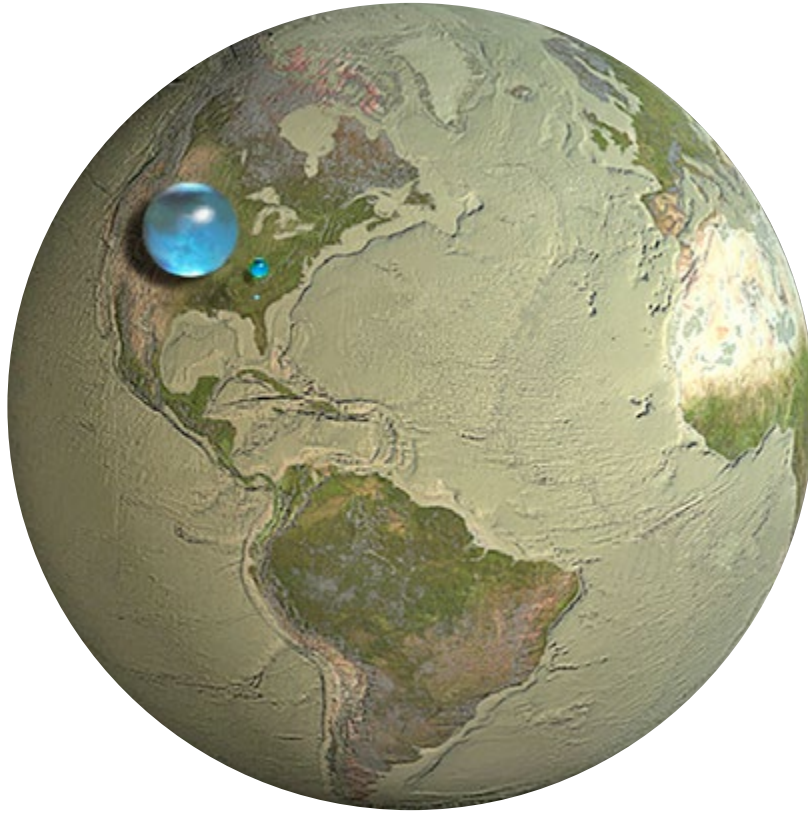

The largest sphere represents all water on, in, and above the Earth.

The smaller sphere represents Earth's total liquid fresh water.

The smallest sphere represents all available fresh water in lakes and rivers.

Howard Perlman, USGS. Jack Cook, Woods Hole Oceanographic Institution  
Data source: Igor Shiklomanov, 1993.  
<http://ga.water.usgs.gov/edu/earthhowmuch.html>

## 4 Virtual water

The concept “virtual water” is abstract and probably difficult for the learners to grasp. The following exercise will help them to gain a better understanding of the concept (Worksheet 3, Exercise 4).

### Last part of the story

The question about “How can we make water last for everyone” is very complex and will probably lead to longer and more informed discussions. Let the learners test different ideas and as their discussion winds down there might be some aspects that the students haven't come up with and which the teacher optionally can raise:

- Eat less meat.
- Plan how you buy and store food to prevent throwing food away.
- Every person's actions matter for the water security for the nation - and the globe!
- A country that imports food also imports water.
- Some countries have a lot, others not...
- Don't buy oranges grown in a desert!
- In many countries much less water is used than in the story. This raises the question of justice. Who has the right to the water available in a specific region? Only those who live there?
- You can sustainably use water from wells only as fast as they are refilled by the rain and gravity.
- Are there any old traditions helping to save water?

## 5 Final conclusions

Exercises 5 and 6 are different examples of how you can wrap up this lesson sequence, depending on available time and your goals.



**Geography**  
 The Story of the Invisible Water  
1  
 worksheet

## The Story of the Invisible Water

In this story there are two actors – **Tim a young school boy (T)** and a **Glass of water (W)**. The dialog between the actors will be interrupted by a number of exercises when the audience discusses or reacts to certain parts of the dialog. The first exercise will be done before the dialog starts as a preparation for the performance.

**Exercise 1 (worksheet 1)**  
 When we start our story the schoolboy Tim is eating breakfast, chatting with his mother. Tim asks for water and his mother hands him two litres in a jug asking him if it is enough. Tim answers, looking into the glass of water he just filled up:

**T:** I think two litres would be enough for a whole day!  
**W:** Two litres is not enough for a whole day!  
**T:** Stop that! You are a glass of water and you should not talk to me!  
**W:** Yes I am a glass of water but in this story I won't keep quiet! As being water I am tired of being treated like air. Two litres is maybe what you drink as pure water, but there is so much water in your life that is invisible. How much of me do you think one person needs?



**Exercise 2 (worksheet 1)**  
 We come back to the story when Tim counts and guesses how much water he uses daily:

**T:** Hmm... If I include the water in a couple of cups of tea, not more than 3 litres anyway!  
**W:** Well, well, well, but you don't use me only for drinking, do you?  
**T:** No, of course, if I count taking a shower and washing my clothes and all the other problems that water can solve in my life maybe a hundred litres per day.  
**W:** Not a bad guess, but many people use 500 litres per day. But we are still only talking about water coming home through a tap of some kind. But don't forget that the water you use is mostly invisible!  
**T:** (irritated) Yes, I know that water can boil or evaporate and become invisible steam, but personally I don't use that form of water!  
**W:** Cool down. Let me ask you a question: How much of me is used to make a slice of toast?  
**T:** (laughing) Aha, a trick question! When you toast bread you take water away from it. That's why it gets so hard!  
**W:** You're right, Tim, but listen, here's the really invisible water in the bread: When the wheat in that bread was a plant it needed a lot of water. Water was also needed to treat the grain, bake and pack the bread. So every slice needed 40 litres of water before it reached your plate.  
**T:** (protesting) It still tasted quite dry!  
**W:** This invisible water sure is tasteless as well as invisible, but it's very real. And it's the same thing for one apple: 70 litres. Or a cup of coffee: 140 litres.  
**T:** Wow, that's more water than I thought I used during the whole day, just for one cup of coffee ...!

**Geography**  
 The Story of the Invisible Water  
2  
 worksheet

## The Story of the Invisible Water

These exercises should be done partly in a group, and partly by yourself. Inspiration and some background information will be presented in the role play "The story of the invisible water". Other necessary facts and tasks will be presented by your teacher in the following lessons.

**1. Water content I**  
 Which of these objects contains most water?  
 Discuss in groups and motivate your answer:

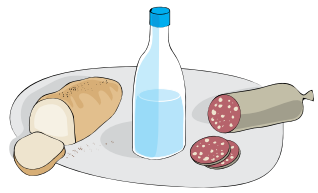

\_\_\_\_\_

\_\_\_\_\_

\_\_\_\_\_

\_\_\_\_\_

**2. Your daily water** Work in groups  
 How much water per person do you use in your group per day?  
 Make a list, sum up the volume and share with the class before the story continues.

Purpose	Amount of water	Purpose	Amount of water
_____	_____	_____	_____
_____	_____	_____	_____
_____	_____	_____	_____
_____	_____	_____	_____
<b>Total sum</b> .....			

**3. Water content II** Short group discussion:  
 a. In the story they speak about invisible or virtual water. Explain the world virtual water!

\_\_\_\_\_

\_\_\_\_\_

\_\_\_\_\_

b. After having heard the second part of the story:  
 Which item from Exercise 1 contains most water? Explain!

\_\_\_\_\_







\_\_\_\_\_

\_\_\_\_\_

**Geography**  
 The Story of the Invisible Water  
3  
 worksheet

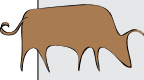
## The Story of the Invisible Water

**4. Virtual water in different products**  
 a. Guess the amount of virtual water in the products below.  
 b. Compare your guesses with some of the guesses of your classmates.  
 c. Add the correct answers from your teacher ([www.virtualwater.eu](http://www.virtualwater.eu)).

	My guess	Correct answer		My guess	Correct answer
					
					
					

d. Personal comments.

\_\_\_\_\_

\_\_\_\_\_

\_\_\_\_\_

**5. A water lean meal**  
 You need appropriate statistics from your teacher or connection to the Internet.

a. Put together a good and nutritious dinner with a small water footprint.  
 b. Compare your results with your classmates.

Valuable links:  
[www.waterfootprint.org](http://www.waterfootprint.org)  
[www.virtualwater.eu](http://www.virtualwater.eu)

**Geography**  
 The Story of the Invisible Water  
4  
 worksheet

## The Story of the Invisible Water

**6. Water for everyone**  
 Write a short newspaper article or make a small poster exhibition under the heading "A fair and sustainable use of our common water!"

- Work in groups of 2–3 persons.
- Decide on the target group of your article or exhibition.
- Discuss how to adapt your material to the target group.
- Use the illustrations below for your inspiration and bring in other facts, figures and concepts you have learned during this course.

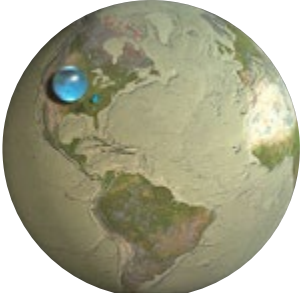

The largest sphere represents all water on, in, and above the Earth.

The smaller sphere represents Earth's total liquid fresh water.

The smallest sphere represents all available fresh water in lakes and rivers.

The map shows the average national water footprint in m<sup>3</sup> per year per capita in the period 1996–2005.

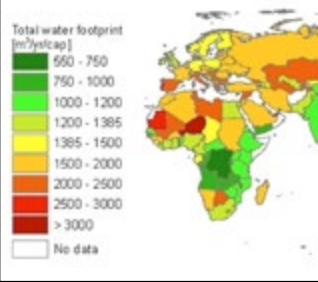

Countries shown in green have a water footprint that is smaller than the global average.

Countries shown in yellow-red have a water footprint larger than the global average.

Valuable links:  
[www.waterfootprint.org](http://www.waterfootprint.org)  
[www.virtualwater.eu](http://www.virtualwater.eu)

Sources  
 The Water in and above Earth: Howard Parman, USGS, Jack Cook, Woods Hole Oceanographic Institution Data source: Igor Shiklomanov, 1993. <http://ga.water.usgs.gov/edu/earthhowmuch.html>  
 Average Water Footprint: Mekonnen, M.M. and Hoekstra, A.Y. (2011) National water footprint accounts: the green, blue and grey water footprints of production and consumption. Value of Water Research Report Series No.50, UNESCO-IHE, Delft, the Netherlands.

# Social Studies

This section addresses the sustainability challenges through social science perspectives, and focuses on environmental responsibility, social/cultural responsibility and economic responsibility to achieve social viability and equity. This learning is divided in three sections:

- Myths and legends
- Consumption
- Scramble

**Myths and legends** touch upon the importance of indigenous knowledge and how it is linked to natural resource management and conservation. It addresses issues of sustainability and challenges through localized stories and folklores. It also focuses on environmental, social and cultural responsibilities to achieve sustainable livelihoods through the conservation of ecosystems. The educators and learners are empowered to appreciate the value and use of indigenous knowledge in natural resource conservation.

**The consumption section** looks at the connection between our consumption choices and our carbon footprint and how they impact on the environment. Some of the factors that influence our food choices include distance travelled, time taken before consumption, whether imported or sourced locally and the kind of packing we get it in. Through discussions learners and educators are capacitated to make informed decisions regarding their food choices. Learners are expected to develop competencies to influence meal choices at home and at a community level. The activity is exciting and promotes team-building.

**The scramble section** presents a way to make learners aware of the world economy and how it affects people with different economic statuses. The distribution of wealth and power within a society usually affects a person's opportunities to achieve full human rights and live a life with dignity. It challenges learners and educators to examine the concepts of "fairness" and "responsibility", enabling them to reflect on their own practices and how they affect others.

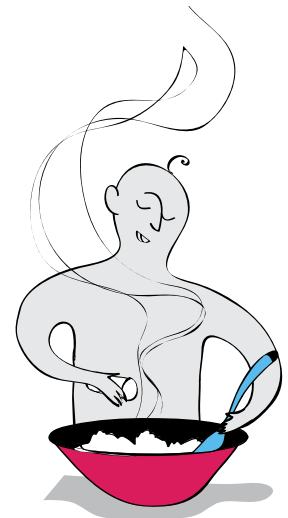
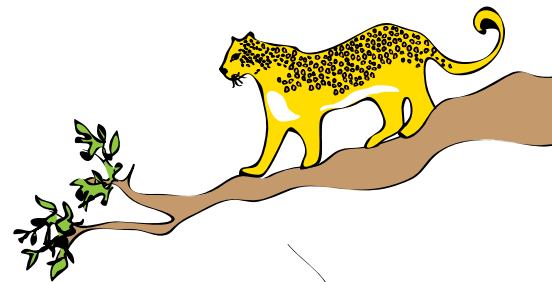

## Objectives

- To help learners to engage with indigenous knowledge.
- To help learners to connect myths and legends to conservation of natural resources.



1.5 hour

# Myths and Legends

## Introduction

This section addresses the sustainability challenges through myths and legends (localized stories and folklores), and focuses on environmental, social and cultural responsibility to achieve sustainable livelihoods through the conservation of ecosystems.

Liaise with older community members to identify folk stories that are linked to ecosystems and their conservation. These could be local or from elsewhere.

Collect different ways of linking indigenous knowledge to the conservation of ecosystems

## Working process

- 1** Reading and discussing the role of local stories and folklore in the conservation of ecosystems.
- 2** Discussing the value of indigenous knowledge (myths and legends) in modern life.
- 3** Application of lessons learnt – learners will share stories that relate to the ideas discussed earlier.

**Social Studies**  
 Myths and Legends  
1  
 worksheet

## Myths and Legends

Example 1 and 2 below are mythical stories that were common in some African customs. Discuss and answer the questions.

**Example 1**  
 In Zimbabwe, there is a tree that was believed to be able to provide food if elders went under its shade and asked for food in times of need. The food would be provided by the gods at the base of the tree. Traditionally the cutting down of that sacred tree was therefore prohibited. Have you heard of similar stories from your area?

**Example 2**  
 In Malawi, killing a leopard was only authorized by the chief of the area. Anyone found killing it would be punished by the chief by banishing him from the area. If an exception was made, then the skin of the leopard was confiscated by the chief.

To discuss the questions below, consider people's respect for traditional stories and their values, myths and how they promote biodiversity and ecosystem services.

**Discussion**

- Using the information provided in the story, one could argue that there are no ecosystem services in this story.
  - Do you agree with this view or not? \_\_\_\_\_
  - Give reasons for your opinions. You should support your answer with examples from your community/country wherever possible.  
 \_\_\_\_\_  
 \_\_\_\_\_  
 \_\_\_\_\_
- What part is played in each of the examples above by trees/animals in providing eco-system services?

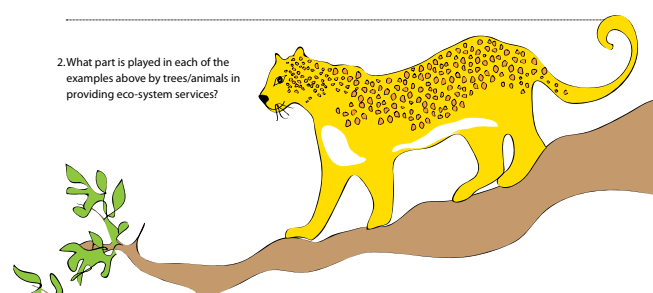

**Social Studies**  
 Myths and Legends  
2  
 worksheet

## Role of Indigenous Knowledge

**Discussion**  
 Some people argue that there is a clash between modern thinking and indigenous knowledge which no longer holds the same respect it used to.

- What role can indigenous knowledge play in the conservation of natural resources?
- What role can you play towards the conservation of biodiversity?
- Using modern ideas and your experiences in life, create a story and a myth that promote conservation of natural resources.
- How can we actively engage everyone in biodiversity conservation?

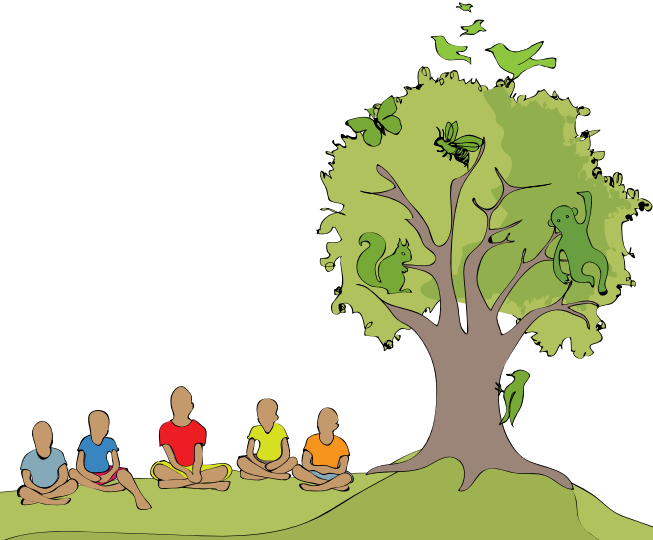

**Social Studies**  
 Myths and Legends  
3  
 worksheet

## Myths and Legends

*Sharing Indigenous Stories*

**Discussion and writing**

**Legend in Sweden**  
 The Vikings dominated the Northern countries in the 8th century. They believed in the Asa gods as part of their religion. The Vikings were a warrior society and if you died fighting you came to Valhalla where all the gods lived. In Valhalla they had a big feast every evening where they feasted on a pig. After they finished the pig meat they collected all the bones and put them in a leather bag. The next day the pig would resurrect. One evening one of the Vikings broke the bones of the pig and ate the marrow. As result of this the next day the pig was not resurrected.

- What sustainability lessons can we pick from this story?
  - Think of other stories that you have heard. Share your story with the rest of the group/class.
  - What is the link between the story and sustainability?
- Using modern ideas and your experiences in life, create a story and a myth that promotes conservation of natural resources.

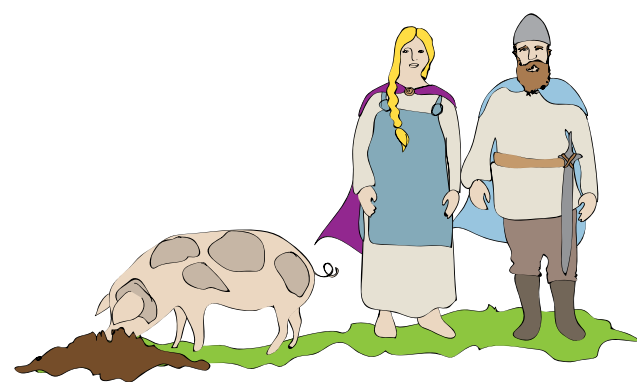

## Objectives

- To provide opportunities for learners to critically assess their consumption choices and to enable them to contribute to strong sustainability.
- To understand the connection between their consumption and its effect on their carbon footprint.



4–6 hours

## Necessary equipment and group size

12–36 learners in 3–4 teams (depending on available cooking facilities)

Each team should be supplied with an Enviro Meal audit sheet, a pencil, a cardboard box and cash with which to buy the food (\$ 3.00 per person)

# Sustainable Consumption

## Introduction

We need to challenge our meal choices in order to achieve sustainable consumption patterns. Reducing our carbon footprint through our consumption options is one way of achieving this goal. Some of the factors that influence our food choices could include:

- how it has been grown,
- how far it has travelled to get to you,
- whether it is in season or if it has been refrigerated for months,
- if it has been flown in from somewhere else,
- whether it is meat or fish,
- and in what kind of packing we get it in.

The Enviro Meal is an educational activity which examines some of the choices we make as consumers around food, packaging and waste, which have an impact on our environment. It can be used as a stand-alone activity or as part of a larger learning programme. The activity is exciting and competitive and lends itself to active participation by everyone involved. In addition to the environmental learning which grows out of the activity, the Enviro Meal is great for team-building!

## Instructions for learners

Your team must plan and prepare a meal, which you will eat together. You will need to purchase all of the necessary ingredients with the money provided by your teacher. Afterwards, your meal will be audited to assess its environmental impact, in terms of food types and packaging. The Enviro Meal audit sheet will be used to assess these impacts. Your team's final score represents the impact of your meal on the environment. The higher the score, the greater the impact.

## Rules

- No ingredients will be provided beforehand. You must purchase everything you need to prepare your meal – including salt, oil, margarine, tomato sauce, drinks, etc.
- You must not add your own money to the money provided.
- Teams are not allowed to exchange or purchase items, such as salt and oil, from each other.
- You are not allowed to purchase pre-cooked foods such as roast chicken, pies or pizza.
- Do not remove any packaging from items, while shopping, to reduce your packaging points.
- Collect and keep all items of packaging, which came with your ingredients, in your cardboard box, nothing should be discarded.
- All purchases should be accompanied by till slips and receipts – keep these for auditing purposes.
- Each team should cater for their teacher and invite him/her to eat with them.

Teachers should speak to shop managers and security personnel beforehand to explain the purpose of the activity and to get permission to do the activity in their store.



## Objectives

Learners should be able to describe the relationship between wealth and power and use it to influence community decisions and participation.



1.5–2 hours

## Necessary equipment

Background information on:

- 1) taxation
- 2) environmental ethics
- 3) IUCN red book data and
- 4) lobbying

# Fairness and Strong Sustainability

## Introduction

The distribution of wealth and power within society usually affects a person's opportunities to achieve full human rights and live a life with dignity. This activity involves the distribution of wealth. It challenges participants to examine the concepts of "fairness" and "responsibility" and reflect on their own actions. This activity explores the relationship between wealth and power and how it affects decisions about access to ecosystem services. It challenges learners to connect social and economic fairness to strong sustainability.

## Worksheet 1: The Scramble

The world's wealth is represented by the 100 coins or tokens.

There is only one rule – no participant may touch another member of the group at any time.

Participants stand or sit in a circle. To begin with two participants will wear gloves, two will have only one free hand and one already has 5 coins. When the game begins, they gather as many coins/tokens as possible without touching another person.

After all the coins/tokens have been collected, participants count the number of coins/tokens they have collected. These will represent their wealth and power. Help them to form three groups according to the wealth they have.

Group 1	Group 2	Group 3
<b>Great wealth and power (GWP)</b>	<b>Some wealth and power (SWP)</b>	<b>Little wealth and power (LWP)</b>
More than 13 coins	6–12 coins	Less than 5 coins
Basic "needs" and most of their "wants" are met	Basic needs are met	Difficulty surviving due to disease, lack of education, malnutrition, and poor shelter

## Worksheet 2: Creating Economic "Fairness"

Instruct each group to create a plan for the fair distribution of the coins/tokens – the world's wealth. You will ask them to vote on the best plan and the following will apply:

- ☒ participants in group 1 have five votes each;
- ☒ those in group 2 have two votes each;
- ☒ those in group 3 have one-half vote each.

The plan that wins the most votes will be carried out, redistributing the wealth if necessary.

## Worksheet 3: Debriefing the Activity

Draw on the questions provided in Worksheet 3 to prepare for a productive discussion. Make sure participants are prepared for a discussion of changes needed and changes undertaken at local, national and global levels.

**Social Studies**  
 Fairness and Strong Sustainability  
 worksheet **1**

## The Scramble

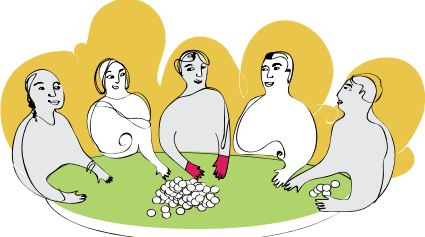

The world's wealth is represented by the 100 coins or tokens.

Participants stand or sit in a circle. To begin with two participants will wear gloves, two will have only one free hand and one already has 5 coins. When you have told them to start, they gather as many coins/tokens as possible. There is only one rule – no learner may touch another member of the group at any time.

- When the teacher tells you to start, gather as many coins/tokens as you can without touching another person.
- Count your coins and write the number down.
- Choose your group by checking (X).  
 If you have more than 13 coins – check Group 1; between 6 and 12 coins check Group 2 and less than 5 coins check Group 3.

<b>Group 1</b>	<b>Group 2</b>	<b>Group 3</b>
More than 13 coins	6–12 coins	Less than 5 coins

---

- Form your group.

<b>Group 1</b>	<b>Group 2</b>	<b>Group 3</b>
Great wealth and power (GWP)	Some wealth and power (SWP)	Little wealth and power (LWP)

**Social Studies**  
 Fairness and Strong Sustainability  
 worksheet **2**

## Creating Economic “Fairness”

Do you think you had a fair share? Create a plan in your group for the fair distribution of the coins/tokens for the whole class (the world's wealth). Describe your plan and explain what needs to be done.

---

---

---

---

---

---

---

---

---

---

Say why your group's plan is fair. \_\_\_\_\_

---

---

---

---

---

---

---

---

---

---

Appoint a spokesperson to explain your group's plan to the others and answer questions from the other groups.

### Voting

My group is **Group 1** **Group 2** **Group 3**

---

I am voting for this plan **Group 1** **Group 2** **Group 3**  
 Plan Plan Plan

---

Use the ballot paper to decide which plan wins the vote. Give a reason why this plan won the vote.

---

---

---

---

---

---

---

---

---

---

**Social Studies**  
 Fairness and Strong Sustainability  
 worksheet **3**

## Ballot Paper

My group is **Group 1** **Group 2** **Group 3**

---

I voted for this plan **Group 1** **Group 2** **Group 3**  
 Plan Plan Plan

---

### Vote calculation

You will now do a calculation of the votes. The following will apply in order to choose the highest rank plan from voting results:

- participants in **Group 1** have **five (5)** votes each,
- those in **Group 2** have **two votes (2)** each, and
- those in **Group 3** have **one-half (1/2)** vote each.

Group 1 plan	No of votes from	Strength of vote
_____	Group 1	x 5 =
_____	Group 2	x 2 =
_____	Group 3	x 0.5 =
Total votes for Group 1 plan .....		

_____	Group 1	x 5 =
_____	Group 2	x 2 =
_____	Group 3	x 0.5 =
Total votes for Group 2 plan .....		

_____	Group 1	x 5 =
_____	Group 2	x 2 =
_____	Group 3	x 0.5 =
Total votes for Group 3 plan .....		

Which plan has won this vote? This is the plan that will be carried out.

**Social Studies**  
 Fairness and Strong Sustainability  
 worksheet **4**

## Debriefing the Activity

Draw on the following questions to prepare for a productive discussion. Make sure you are prepared for a discussion of changes needed and changes undertaken.

- How do inequalities of distribution relate to other current issues like environmental destruction?
- Is there a connection between fairness and sustainability?
- What aspects of this game represent how the world's wealth and power are distributed?
- Some participants were wearing gloves, others had only one free hand and one person already had 5 coins. How does this game help a better understanding of the situation or attitude of poor people/nations? Of the situation or attitude of wealthy people/nations?
- Why were some people given more votes than others? Was this an accurate representation of those with more or less power in the world?
- Who are the “haves” and the “have nots” in the world today? Which countries are the “haves” and the “have nots”? Who are the “haves” and “have nots” in our country today? In our state or community? Why?
- Why should the “haves” be concerned about the situation of the “have nots”? For what reasons? Economic? Moral/religious? Political? Why might the “haves” give money or resources to the “have nots”? Is this a way to solve the problems of poverty?
- Do you think there should be a redistribution of wealth and power throughout the world? Why or why not? If yes, how would you propose to accomplish this? What principles would guide your proposals for change?

### Writing

Write a short essay with the title “How fairness in resource distribution can help to achieve sustainability?” to express your opinion on the distribution of wealth and power in your country or in the world.

You may want to consider the following to guide you:

- What is economic fairness to you?
- Describe how you felt about the relative position you achieved in the activity.
- Are there responsibilities associated with having wealth and power?
- How do wealth and power affect one's ability to enjoy human rights and human dignity?
- Should poor countries pay back their debts? What would happen if they did not have to pay them back?

### Group discussion and poster design

In groups of four learners discuss the question: What is the connection between fairness and sustainability? Then each group designs a poster.





# Business Studies

**E**conomic and social responsibility is the contribution by individuals and organisations in an attempt to maintain a balance between the economy, society and ecosystems. Trade-offs always exist between economic development, in the material sense, the welfare of the society and the environment. Responsible business pertains to both business organisations and everyone whose actions impact on the environment. This responsibility can be passive, by avoiding engaging in socially harmful acts, or active, by performing activities that directly advance social goals. The exercises present facilitators and learners with various ways to apply their social and economic responsibility with the intention of influencing those actions that encourage the balance between business activities on the one hand and social and ecological systems on the other.



### **Fair trade chocolate**

This is an economic exercise which explores the Fair Trade concept by tracing chocolate's journey from the cocoa farm to the chocolate in the shops. It challenges learners to consider that every time they eat chocolate, hard-working farmers that live in faraway places are sharing something special with them.



### **How are cell phones and the African gorilla connected**

This exercise explores the relationships between industry and nature using the example of the link between cell phones and ecosystem services in the DRC. It challenges learners to imagine African mineral wealth as a curse or a blessing.



### **Economic responsibility**

This is an economic valuation exercise which promotes the health of ecosystems as valuable sources of products and services. The activity explores the value of an ecosystem service across social, political and economic classes. It challenges learners to reflect on their own actions and to initiate responsible behaviour in the community.

## Objectives

- To identify where our money goes when we buy both unfairly and fairly traded chocolate.
- To develop an understanding of some principles of fair trade as a sustainable alternative.



1.5–2 hours



# Chocolate, Slavery and Fair Trade

## Introduction

Do you know that cocoa which grows in faraway places becomes the chocolate you buy in the store? It begins with cocoa farmers. Every time you eat chocolate, hard-working farmers and farm workers that live in these faraway places are sharing something special with you.

Chocolate is made of cocoa which comes from cocoa beans. Cocoa beans grow on cocoa trees, inside pods that are the size and shape of a rugby ball.

Sometimes the farm workers are children. They have to work very hard on cocoa farms all day because their parents are too poor to afford to send their children to school or hire enough people to work on the farm. They do not get to go to school or play very much. They may even get hurt while they are working on the farm.

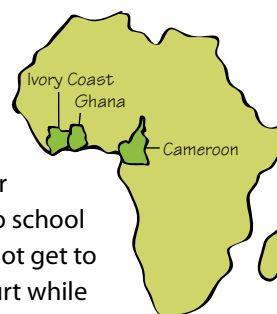

The Fair Trade organization is trying to improve the social status of cocoa farmers. Some of the Fair Trade cocoa is grown in Cameroon, Ghana and the Ivory Coast.

The price we pay in the shop for a \$ 1.00 bar of chocolate is divided something like this:

Group	Dollars (\$)	Percentage
Shops	0.20	20
Chocolate companies	0.45	45
Government (VAT)	0.15	15
Non-cocoa ingredients and costs	0.19	19
Farmers	0.01	1

## Working process

Before the lessons, learners should be introduced to the chocolate "journey" so that they understand the different stages and groups involved in trading cocoa and making chocolate. The following worksheets will take learners through three steps as shown below.

- Worksheet 1.** An activity exploring the income received by different groups in the chocolate producing and trading process. What might be some of the consequences of this distribution? Learners should consider and discuss who they think works the hardest.
- Worksheet 2.** Why do cocoa farmers make such a small amount of money and what are the social and ecological impacts arising from the chocolate industry?
- Worksheet 3.** What can you do to help the situation?

**Business Studies**  
 Chocolate, Slavery and Fair Trade  
 worksheet **1**

## Chocolate, Slavery and Fair Trade

*Where does our Money Go?*

**Activity 1**  
**Stakeholder shares of a 20 square chocolate bar**  
 The price we pay in the shop for a bar of chocolate is divided into something like the table below. If the 20 square chocolate bar represents where our money goes, how many blocks do each of the following groups receive?

Group	Percentage	Chocolate blocks
Shops	_____	_____
Chocolate companies	_____	_____
Government (VAT)	_____	_____
Non-cocoa ingredients and costs	_____	_____
Cocoa Farmers	_____	_____

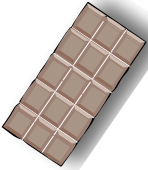

Convert the table to a pie chart to show where our money goes when we buy chocolate, and what percentages go to each group. Add more information to each segment to explain what it does, e.g. Shops – pays wages to shop workers. Use a separate paper for the pie chart.

Who decides the chocolate stakeholder shares and why?

\_\_\_\_\_

\_\_\_\_\_

Can you think of three reasons why the percentage paid to farmers for their cocoa beans is so low?

\_\_\_\_\_

\_\_\_\_\_

\_\_\_\_\_

**Business Studies**  
 Chocolate, Slavery and Fair Trade  
 worksheet **2**

## Chocolate, Slavery and Fair Trade

*Social and Ecological Impacts*

Use these lines for your notes and write your answers on a separate paper.

**Activity 2**  
**Social Impact**

- Describe at least two social consequences resulting from farmers being paid so little for their cocoa beans?  
 \_\_\_\_\_  
 \_\_\_\_\_
- Many cocoa farmers and their children have never eaten chocolate. What is your comment?  
 \_\_\_\_\_  
 \_\_\_\_\_

**Slavery**

- There are even some cocoa farm workers who are not paid at all for their work. A worker who is not paid is called a slave. Slaves on cocoa farms are often children, brought to work far from their homes and families. Describe what you think about this.  
 \_\_\_\_\_  
 \_\_\_\_\_



**Ecological impact. Monoculture and deforestation.**

- Another problem that can happen with cocoa farming is that the forest gets cut down to grow more cocoa to sell. Sometimes people create plantations or large farms of cocoa trees. Why could this be a problem?  
 \_\_\_\_\_  
 \_\_\_\_\_

**Chemicals**

- Cocoa trees do not grow well outside the forest so farmers on the big cocoa farms use large amounts of chemicals called pesticides to keep away bugs and diseases. They also use fertilizers that make plants grow faster. How may this be a problem?  
 \_\_\_\_\_  
 \_\_\_\_\_

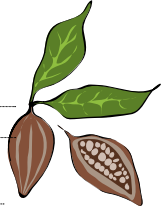
- In what ways do you think farmers could protect the environment if they get more money for their cocoa?  
 \_\_\_\_\_  
 \_\_\_\_\_

**Business Studies**  
 Chocolate, Slavery and Fair Trade  
 worksheet **3**

## Chocolate, Slavery and Fair Trade

*What can You Do?*

Use this text-sheet for your notes and write your answers on a separate paper.

**Activity 3**  
**Where does our money go?**

Typical Chocolate Bar

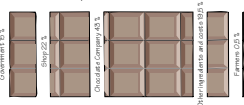

Fair Trade Chocolate Bar



Using the information above, calculate the breakdown of the cost for each of the following chocolate bars:

**Cost: 45 cents**

Government VAT: \_\_\_\_\_

Shop or Supermarket: \_\_\_\_\_

Chocolate company: \_\_\_\_\_

Other ingredients: \_\_\_\_\_

Farmers: \_\_\_\_\_

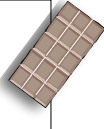

**Cost: 55 cents**

Government VAT: \_\_\_\_\_

Shop or Supermarket: \_\_\_\_\_

Chocolate company: \_\_\_\_\_

Other ingredients: \_\_\_\_\_

Farmers: \_\_\_\_\_



- Think about the words **Fair** and **Trade** then write down your understanding of Fair Trade.  
 \_\_\_\_\_  
 \_\_\_\_\_
- Describe at least three problems of marketing/selling fair trade products?  
 \_\_\_\_\_  
 \_\_\_\_\_
- What do you think you can do to get supermarkets and shops to sell Fair Trade chocolate?  
 \_\_\_\_\_  
 \_\_\_\_\_

**Campaign**

How can you persuade your friends and family to buy Fair Trade products? Think of three good arguments.

\_\_\_\_\_

\_\_\_\_\_

\_\_\_\_\_

You can start with **your class**, then **your school**... At home you start with **your family**, then **your community**...

## Business Studies

*Cell phone utility  
Demand and supply  
Conflict and ecosystem  
services  
Blessing and curse of  
mineral resources*

### Objectives

Learners should be able to

- develop critical thinking skills regarding increasing consumption lifestyles, in this case cell phones.
- initiate responsible behaviour towards economic and social justice through environmental protection.



1.5–2 hours

# Cell Phones, Gorillas and Armed Conflicts

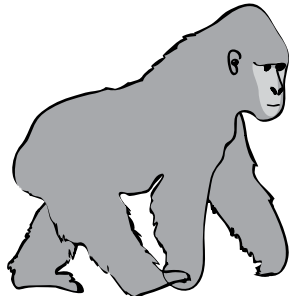

## Introduction

Have you ever thought of the relationships between industry and nature? One example is the link between cell phones and ecosystem services. Can you imagine the relationship between the African forest gorillas, cell phones and armed conflicts?

If you own a cell phone you probably own a part of the Democratic Republic of Congo (DRC). A key element essential for cell phones is called coltan (Columbite-tantalite). 80 % of the world coltan reserves are in the deep forests of DRC. The place where coltan is mined is also home to the world's endangered lowland gorillas. As the cell phone market expands, huge numbers of older models are discarded.

Some of the biggest users of coltan from the DRC are Sony, Microsoft, Hewlett-Packard, IBM, Nokia, Intel Lucent, Motorola, Ericsson, Siemens, Intel, Hitachi, IBM, etc. What kind of phone do you own?

The following lesson activities will help the learners to understand the relationship between global market forces, politics and protection of ecological environments. You will need background information on the local and global supply and demand of cell phones.



**Business Studies**  
 Cell Phones, Gorillas and Armed Conflicts  
1  
 worksheet

## Cell Phones, Gorillas and Armed Conflicts *Electronic Waste*

**Activity 1**

Background information

By 2009 there were more than **five billion** cell phone connections worldwide. (It will take you 32 years to count to one billion.)

The average life span of a cell phone is only **14 months**. It is estimated that **426 000** cell phones go out of use every day. That totals to about **155 million** a year.

Only **10%** of the cell phones are recycled and it can be estimated that around **140 million** cell phones are thrown out each year.

**Recycling cell phones** protects landfills from the many potentially hazardous chemicals found in the phones, including antimony, arsenic, copper, cadmium, lead, and zinc.

- How many phones have you owned in your life time? .....
- What is the longest time you have had with your cell phone? .....
- How many cell phones will you have owned by the time you are sixty years old? .....
- Can you name three alternatives to throwing out your cell phone? .....

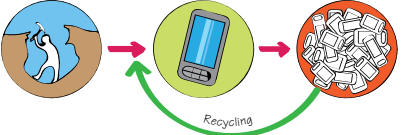

1. Put three labels on the diagram to show the process

- What is the problem with this linear process of production? .....
- Describe and explain three ways that may help us to reduce the problem. ....

**Business Studies**  
 Cell Phones, Gorillas and Armed Conflicts  
2  
 worksheet

## Cell Phones, Gorillas and Armed Conflicts *A Blessing or a Curse?*

**Activity 2**

**Discussion topics on economic pressure versus the ecological environment**  
 As the need for coltan continues to grow, uncontrolled mining practices in the DRC will continue to damage the already endangered lowland gorilla.

The population of gorillas has declined from about **9,000** in 1996 to just about **3,000** individuals today.

Armed groups in the region are operating mines which have paved the way for large-scale **destruction of rain forests** in the area, effectively decimating the gorillas' natural habitat.

Mining has also attracted more than **10,000 illegal miners** into protected parks.

**Discussion questions**

- The value of cell phones as a means of communication is coming at the cost of whole species and important habitats.
- In your opinion what is causing the conflict in the DRC?
- Describe and explain how cell phone users are helping the conflict in the Congo?
- What do we lose if the lowland gorilla becomes extinct? Can you describe the connection between the plight of gorillas in the DRC and the huge worldwide demand for cell phones?



**Business Studies**  
 Cell Phones, Gorillas and Armed Conflicts  
3  
 worksheet

## Cell Phones, Gorillas and Armed Conflicts *Do Something!*

**Activity 3**

**Discussion topics on possible solutions (agency)**  
 What can be done to deal with the issues discussed so far?

We have all heard of "Dolphin safe tuna". Hopefully, we will soon hear about "Gorilla Safe cell phones".

Resell your cell phone. Some cell phone companies take unused cell phones and refurbish them, then sell them to developing markets in Latin America and Africa. How do you feel about this?

**Compile a project portfolio or design a poster**  
 Resources in ecologically sensitive areas can be a curse instead of a blessing. Choose one resource that in your opinion has turned out to be a curse rather than a blessing to the local people.

Compile a project portfolio or design a poster to show how this has happened. Remember to offer some possible solutions.

**E-waste**  
 Discuss how the recycling of electronic waste can be problematic.

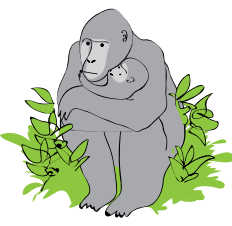

## Objectives

Learners should be able to initiate responsibility for environmental protection in their community.



1.5–2 hours

## Necessary equipment

Background information on:

- 1) taxation
- 2) environmental ethics
- 3) IUCN red data book and
- 4) lobbying

# Economic Responsibility

## Introduction

Healthy ecosystems are a valuable source of products and services. Smart use of ecosystem goods and services can lead to strong sustainability and make a positive contribution to the global socio-economic system. This activity explores the value of an ecosystem service across social, political and economic classes. It challenges learners to reflect on their own actions and to initiate responsible behaviour in the community.

## Setting the scene

Participants will work in groups of five. Each participant is assigned a role to play in which the learner is given one of the following pieces of information. The learner must not reveal it to the others at this stage.

### 1. Peasant farmer whose crop is worth one's month salary/income, are destroyed every year because of grazing antelopes

*Knowledge prior to exercise:*

- The antelope is protected by law.
- Damage caused from grazing: 1 month salary/income.
- Monthly salary/income: \$ 50.

### 2. Ecologist working for an NGO trying to protect the antelope

*Knowledge prior to exercise:*

- The antelope is protected by law.
- The scent from one of the antelope's glands is worth \$ 200 on the illegal trade market.
- Price for skin: \$ 50.
- Only 500 adult animals remain according to IUCN's red data book.
- The antelope is decreasing by around 60 adult animals every year.
- Monthly salary/income: \$ 1000.

### 3. Poacher

*Knowledge prior to exercise:*

- The antelope is protected by law.
- The scent from one of the antelope's glands is worth \$ 200 on the illegal trade market.
- Risk of getting caught if poaching: 10 %.
- Number of antelope poached each month: 5.
- Monthly salary/income: \$ 200.

### 4. Municipal officer

*Knowledge prior to exercise:*

- The antelope is protected by law.
- There is some previous tax revenue because of grazing by antelopes in the fields.
- There are some income possibilities from international NGOs coming to the area to protect the antelope.
- According to people in the area, at least 3000 adult animals remain, but NGOs say it's only 500.
- Monthly salary/income: \$ 200.

## 5. Hotel manager in area

*Knowledge prior to exercise:*

- The antelope is protected by law.
- Monthly revenue from tourists visiting the area to see the antelope: \$ 100, but it decreases by \$ 10 every year because the number of antelopes decreases.
- According to people in the area, at least 3000 adult animals remain.
- The antelope is decreasing by around 60 adult animals every year.
- Monthly salary/income: \$ 400.

## Working process

### 1 **The local government decides to collect a tax that will be used for protection measures that will keep the antelope population stable at the present level (this is the so-called payment vehicle).**

**The question to each participant is the following:**

Keeping your monthly income in mind, how much would you be willing to pay in taxes for this cause?

- Each participant writes down his or her valuation without telling the others and gives it to the facilitator.
- Break, giving the facilitator time to summarise valuations.

### 2 **Now the group deliberates freely. Each participant shares the knowledge he or she has about the antelope. The setting is the same as before the break.**

**The question to each participant is the following:**

- What would be an appropriate tax rate for the cause of protecting the antelope (expressed as a percentage of monthly income)?
- Do you see other possibilities of governing the stock of antelopes?

Each group presents its proposal.

### 3 **Discuss results from a strict utilitarian point of view. Discuss marginal utility of money? Link to governance of ecosystem services.**

### 4 **Writing / Poster competition**

Using the experience from the activity, participants can write an essay or design a poster. Participants can also have a poster competition as a group assignment.



**Business Studies**  
 Economic Responsibility  
 worksheet **1**

## Economic Responsibility

*Why Protect the Antelope?*

The local government will decide on a tax that will be used for conservation measures that will keep the antelope population stable at present level. Keeping your monthly income in mind, how much would you be willing to pay in taxes for this cause?

**Activity 1**  
**Group activity (in a group of five)**  
 Decide the amount of tax you are willing to pay (your valuation) without telling the others and give it to the facilitator.

My occupation \_\_\_\_\_

I am willing to pay this much \_\_\_\_\_

Write down your reasons for choosing this amount \_\_\_\_\_

\_\_\_\_\_

\_\_\_\_\_

\_\_\_\_\_

\_\_\_\_\_

**Activity 2**  
**Group discussion (in a group of five)**  
 1. Share your knowledge about the antelope.  
 Each representative will now share what they know about the antelope.

2. Each group will now discuss the following:  
 What would be an appropriate tax rate for the cause of protecting the antelope (expressed as a percentage of monthly income)?

\_\_\_\_\_

\_\_\_\_\_

\_\_\_\_\_

What other possibilities can be considered for governing the stock of antelopes?

\_\_\_\_\_

\_\_\_\_\_



**Business Studies**  
 Economic Responsibility  
 worksheet **2**

## Economic Responsibility

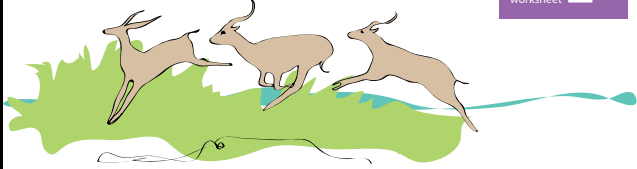

**Activity 3**  
**Plenary group presentations and discussion**  
 1. Each group will now present their proposal.

2. Plenary discussion.  
 Discuss the results from a strictly utilitarian point of view.

What is the marginal utility (usefulness) of money? \_\_\_\_\_

\_\_\_\_\_

\_\_\_\_\_

\_\_\_\_\_

\_\_\_\_\_

How is the utility on money linked to governance of ecosystem services? \_\_\_\_\_

\_\_\_\_\_

\_\_\_\_\_

\_\_\_\_\_

\_\_\_\_\_

Answer these questions:

- What is tax fairness to you?
- Describe how you felt about the tax you have to pay in the activity?
- Are there responsibilities associated with having different jobs and power?
- How do wealth and power affect one's ability to enjoy ecosystem services?
- Should rich countries help poor countries to protect their ecosystem services?

or

- Design a poster.

This publication is produced as a contribution to the United Nations Decade on Education for Sustainable Development and aims to provide support to teacher educators who are striving to mainstream environment and sustainability education. Teacher education experience informing this publication was drawn from South Africa, Swaziland, Sweden, Zambia and Zimbabwe. This publication is a product of SWEDESD, the Swedish International Centre of Education for Sustainable Development, funded by Sida, the Swedish International Development Cooperation Agency.

The publication has two parts:

The first part is a teacher educators' manual that outlines examples with a holistic approach to environmental and sustainability education. Examples are selected as a starting point for establishing links among different subject matters.

The second part is in the form of a file containing a set of worksheets to be used together with learners' activities. The worksheets cover three sections: holistic examples cutting across subject matters, natural science examples (Physics, Chemistry and Biology) and social science examples (Geography, Social Studies and Business Studies).